

2008 Special Design Provisions for Wind and Seismic

Philip Line, P.E., Bradford K. Douglas, P.E., and Peter Mazikins, P.Eng.

Introduction

The 2008 edition of the *Special Design Provisions for Wind and Seismic (SDPWS)* was approved as an American National Standard on August 4, 2008, with a designation *ANSI/AF&PA SDPWS-2008*. The 2008 SDPWS was developed by AF&PA's Wood Design Standards Committee and contains provisions for design of wood members, fasteners, and assemblies to resist wind and seismic forces. Several additions and revisions to the specification have been incorporated in this latest edition.

Additions include:

- High load diaphragms using wood structural panels
- Shear walls using wood structural panels applied over gypsum wallboard or gypsum sheathing board
- Shear strength reduction equation for perforated shear wall shear resistance
- Framing and nailing limits for shear walls sheathed on two sides
- Shear wall framing option to allow two 2x nominal members as an alternative to a single 3x nominal member
- Gypsum lath and plaster walls with vertical joints staggered
- Unblocked wood structural panel shear walls
- Combined uplift and shear resistance of wood structural panels resisting wind loads.

Revisions to existing provisions include:

- Plate washer requirements at foundation anchor bolts
- Aspect ratio limits and construction requirements for structural fiberboard shear walls
- Format of diaphragm and shear wall tables for wood structural panels (plywood and oriented strandboard [OSB])
- Updated references to product standards.

High Load Diaphragms

Provisions for wood structural panel blocked diaphragms with multiple rows of fasteners, also known as "high load diaphragms" have been added consistent with provisions in the 2006 *International Building Code (IBC)* and the 2003 *National Earthquake Hazard Reduction Program (NEHRP)* provisions. A distinguishing feature of high load diaphragms, relative to typical blocked wood structural panel diaphragms, is use of nominal 3x or 4x framing at adjoining panel edges and boundaries and presence of

multiple rows of fasteners at these locations (**Fig. 1**). Apparent shear stiffness values are tabulated for each combination of nailing and sheathing thickness as is done for typical blocked and unblocked diaphragms in the SDPWS to simplify calculation of diaphragm deflection.

Shear Walls – Wood Structural Panels Installed Over Gypsum Wallboard or Gypsum Sheathing Board

Provisions for wood structural panels applied over gypsum wallboard or gypsum sheathing have been added consistent with provisions in *IBC* and the 2003 *NEHRP* provisions. Unit shear strength and apparent shear stiffness values are provided in Table 4.3B for each combination of nailing and sheathing thickness.

Specific provisions of the SDPWS read as follows:

4.3.7.2 Shear Walls using Wood Structural Panels over Gypsum Wallboard or Gypsum Sheathing Board:

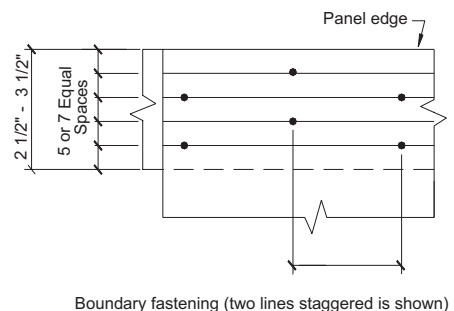
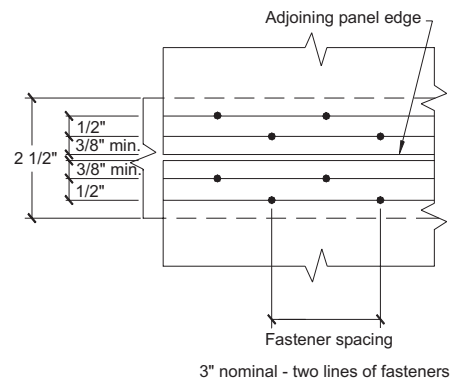

Figure 1.—Excerpt from SDPWS Figure 4C – high load diaphragm.

Shear walls sheathed with wood structural panel sheathing over gypsum wallboard or gypsum sheathing board shall be permitted to be used to resist seismic and wind forces. The size and spacing of fasteners at shear wall boundaries and panel edges shall be as provided in Table 4.3B. The shear wall shall be constructed in accordance with Section 4.3.7.1.

Shear Strength Reduction Equation for Perforated Shear Wall

Equation 4.3-5 has been added to *SDPWS* to provide more accurate results for perforated shear walls having openings of different heights within the wall length. Equation 4.3-5 was the basis for tabulated shear capacity adjustment factors in the current *SDPWS*; however, for tabulation purposes all openings in the perforated shear wall were assumed to have a height equal to the maximum opening height. Use of the equation will always provide values of the shear capacity adjustment factor that are equal to or greater than obtained from the table.

Specific provisions of the *SDPWS* read as follows:

4.3.3.5 Shear Capacity of Perforated Shear Walls: The nominal shear capacity of a perforated shear wall shall be taken as the tabulated nominal unit shear capacity multiplied by the sum of the shear wall segment lengths, $\sum L_i$, and the appropriate shear capacity adjustment factor, C_o , from Table 4.3.3.5 or calculated using the following equation:

$$C_o = \left(\frac{r}{3 - 2r} \right) \frac{L_{tot}}{\sum L_i} \quad (4.3-5)$$

$$r = \frac{1}{1 + \frac{A_o}{h \sum L_i}} \quad (4.3-6)$$

where:

- r = sheathing area ratio
- L_{tot} = total length of a perforated shear wall including the lengths of perforated shear wall segments and the lengths of segments containing openings, ft
- A_o = total area of openings in the perforated shear wall where individual opening areas are calculated as the opening width times the clear opening height. Where sheathing is not applied to framing above or below the opening, these areas shall be included in the total area of openings. Where the opening height is less than $h/3$, an opening height of $h/3$ shall be used, ft^2
- h = height of the perforated shear wall, ft
- $\sum L_i$ = sum of perforated shear wall segment lengths, ft

Framing and Nailing for Shear Walls Sheathed on Two Sides

New provisions for staggering of adjoining panel edges and minimum nominal framing width for two-sided wood structural panel shear walls (Fig. 2) with nail spacing less than 6 in. on center are consistent with similar provisions in the *2006 IBC*. Staggered nailing at adjoining panel edges where 3 in. nominal or wider framing is used is also added. This new provision appears under footnote 6 of Table 4.3A and footnote 5 of Table 4.3B:

Table 4.3A

Footnote 6. Where panels are applied on both faces of a shear wall and nail spacing is less than 6 in. on center on either side, panel joints shall be offset to fall on different framing members. Alternatively, the width of the nailed face of framing members shall be 3 in. nominal or greater at adjoining panel edges and nails at all panel edges shall be staggered.

Shear Wall Construction – Two 2x Members as an Alternative to a Single 3x Member

Use of two 2x framing members adequately fastened together in place of a single 3x member required at adjoining panel edges in shear wall construction is consistent with guidance in the *2005 SDPWS Commentary* as well as a similar provision in the *2006 IBC*. To address proper fabrication where nail spacing in the “stitched” members at adjoining panel edges is close, staggered nailing is required where fastener spacing is closer than 4 in. on center.

Specific provisions of the *SDPWS* read as follows:

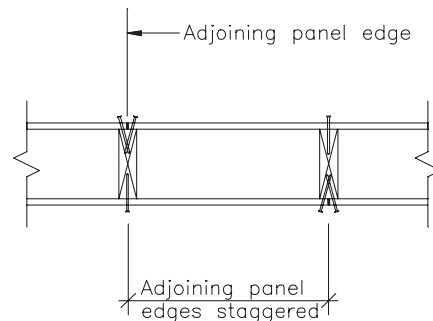

a. Adjoining panel edges staggered

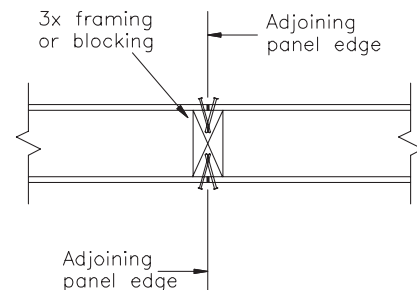

b. Adjoining panel edges not staggered

Figure 2.—Wood structural panel sheathing on two sides.

4.3.7.1 Wood Structural Panel Shear Walls: Shear walls sheathed with wood structural panel sheathing.....

Exception: Where the width of the nailed face of framing members is required to be 3 in. nominal, two framing members that are 2 in. in nominal thickness shall be permitted to be used provided they are fastened together with fasteners designed in accordance with the *NDS*[®] to transfer the induced shear between members. When fasteners connecting the two framing members are spaced less than 4 in. on center, they shall be staggered.

Unblocked Shear Walls

New provisions for unblocked wood structural panel shear walls 16 ft in height or less, aspect ratio of 2:1 or less, and panel edge nail spacing of 6 in. on center. Unblocked shear wall adjustment factors, ranging in value from 0.4 to 1.0, reduce the strength of the reference blocked shear wall with studs at 24 in. on center to account for the presence of unblocked panel edges.

Specific provisions of the *SDPWS* read as follows:

SHEAR WALL, UNBLOCKED. A shear wall that has fasteners at boundaries and vertical framing members only. Blocking between vertical framing members at adjacent panel edges is not included.

4.3.3.2 Unblocked Wood Structural Panel Shear Walls: ... The nominal unit shear capacity of an unblocked wood structural panel shear wall, v_{ub} , shall be calculated using the following equation:

$$v_{ub} = v_b C_{ub} \tag{4.3-2}$$

where:

C_{ub} = Unblocked shear wall adjustment factor from Table 4.3.3.2 (**Table 1**)

v_b = Nominal unit shear capacity (lb/ft) from Table 4.3A for wood structural panel blocked shear walls with 24 in. stud spacing and nails spaced at 6 in. on center at panel edges.

v_{ub} = Nominal unit shear capacity (lb/ft) for unblocked shear wall.

Unblocked shear walls exhibit load-deflection behavior similar to that of the blocked shear wall reference condition but with reduced values of strength based on application of C_{ub} . To account for reduction in unblocked shear wall stiffness, which is proportional to reduction in strength, *SDPWS* 4.3.2.2 specifies that deflection of unblocked shear walls is to be calculated from standard deflection equations using an amplified value of induced unit shear equal to v/C_{ub} as follows:

4.3.2.2 Deflection of Unblocked Wood Structural Panel Shear Walls: The deflection of an unblocked wood structural panel shear wall shall be permitted to be calculated in accordance with 4.3.2 using a G_a for 24 in.

Table 1.—*SDPWS* Table 4.3.3.2.—Unblocked shear wall adjustment factor, C_{ub} .

Nail spacing (in.)		Stud spacing (in.)			
Supported edges	Intermediate framing	12	16	20	24
6	6	1.0	0.8	0.6	0.5
6	12	0.8	0.6	0.5	0.4

stud spacing and nails spaced at 6 in. on center at panel edges and 12 in. on center at intermediate framing members. The induced unit shear, v , in pounds per foot used in Equation 4.3-1 shall be divided by C_{ub} , from Table 4.3.3.2.

Combined Uplift and Shear Resistance of Wood Structural Panels Resisting Wind Loads

Provisions for wood structural panels designed to resist combined shear and uplift from wind have been added in Section 4.4 and update similar provisions first recognized in the *Standard for Hurricane Resistant Construction, SSTD-10* since 1999. Tabulated values of nominal uplift capacity (**Table 2**) for various combinations of nailing schedules and panel type and thickness establish limits based on calculations in accordance with the *National Design Specification*[®] (*NDS*) for *Wood Construction, 2005* and conditions verified by full-scale testing. Allowable values of uplift capacity are determined by dividing the nominal values by the allowable stress design (ASD) reduction factor of 2.0.

Detailing options for use of wood structural panels to transfer tension forces within a story or between stories are provided. Figure 4G (**Fig. 3**) provides minimum distance from top and bottom edges of wood structural panels used to resist tension and spanning from the top plate to the bottom plate within a single story.

Gypsum Lath and Plaster Walls

A new category of shear walls using gypsum lath, plain or perforated, has been added in Table 4.3C (**Table 3**) to recognize increased unit shear capacity and stiffness of this wall type where vertical joints in the gypsum lath are staggered. Unit shear values are based on cyclic testing and are consistent with a similar revision accepted in the *2007 Supplement to the 2006 IBC*.

Foundation Anchorage

Revised provisions for plate washer size and location are specified for anchoring of wall bottom plates. Increase in washer size, from 2-1/2 in. square in the *2005 SDPWS* to 3 in. square in the *2008 SDPWS*, makes washer size consistent with *2006 IBC* and *2006 International Residential Code (IRC)* and provides specific allowance for the slot to facilitate washer placement. Specific provisions of the *SDPWS* read as follows:

4.3.6.4.3 Anchor Bolts: Foundation anchor bolts shall have a steel plate washer under each nut not less than

Table 2.—SDPWS Table 4.4.1.—Nominal uplift capacity of 7/16 in. minimum wood structural panel sheathing or siding when used for both shear walls and wind uplift simultaneously over framing with a specific gravity of 0.42 or greater.^a

Nails	Nail Spacing required for shear wall design											
	6d common nail 6 in. panel edge spacing 12 in. field spacing			8d common nail 6 in. panel edge spacing 12 in. field spacing			8d common nail 4 in. panel edge spacing 12 in. field spacing			10d common nail 6 in. panel edge spacing 12 in. field spacing		
	Alternate nail spacing at top and bottom plate edges											
	6 in.	4 in.	3 in.	6 in.	4 in.	3 in.	6 in.	4 in.	3 in.	6 in.	4 in.	3 in.
	Uplift capacity (plf) of wood structural panel sheathing or siding ^{b,c}											
Single Row ^d	0	168	336	0	216	432	NA	0	216	0	262	524
Double Row ^e	336	672	1008	432	864	1296	216	648	1080	524	1048	1572

^a Nominal unit uplift capacities shall be adjusted in accordance with 4.4.1 to determine ASD allowable unit uplift capacity and LRFD factored unit resistance. Anchors shall be installed in accordance with this section. See Appendix A for common nail dimensions.

^b Where framing has a specific gravity of 0.49 or greater, uplift values in Table 4.4.1 shall be permitted to be multiplied by 1.08.

^c Where nail size is 6d common or 8d common, the tabulated uplift values are applicable to 7/16 in. minimum OSB panels or 15/32 in. minimum plywood with species of plies having a specific gravity of 0.49 or greater. Where nail size is 10d common, the tabulated uplift values are applicable to 15/32 in. minimum OSB or plywood with a species of plies having a specific gravity of 0.49 or greater. For plywood with other species, multiply the tabulated uplift values by 0.90.

^d Wood structural panels shall overlap the top member of the double top plate and bottom plate by 1-1/2 in. and a single row of fasteners shall be placed 3/4 in. from the panel edge.

^e Wood structural panels shall overlap the top member of the double top plate and bottom plate by 1-1/2 in. Rows of fasteners shall be 1/2 in. apart with a minimum edge distance of 1/2 in. Each row shall have nails at the specified spacing.

Figure 3.—SDPWS Figure 4G.—Panel attachment.

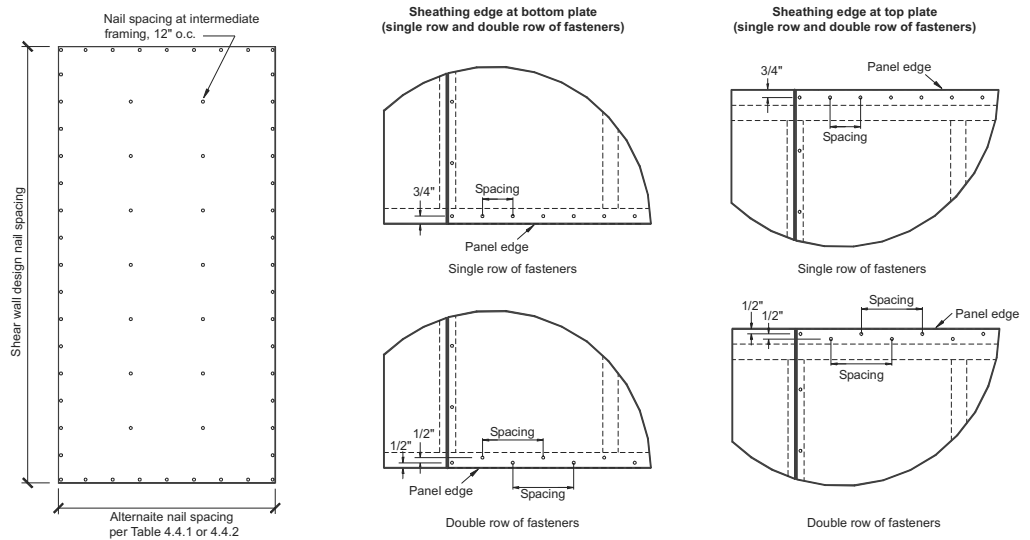

Table 3.—Excerpt from SDPWS Table 4.3C.

Sheathing material	Material thickness	Fastener type and size	Max. fastener edge spacing (in.)	Max. stud spacing (in.)	Seismic		Wind
					v_s (plf)	G_a (kips/in.)	v_w (plf)
Gypsum lath, plain or perforated with vertical joints staggered	3/8 in. lath and 1/2 in. plaster	0.092 in. by 1-1/8 in. long, 19/64 in. head, gypsum wallboard blued nail or 0.120 in. nail by 1-1/4 in. long, min. 3/8 in. head	5	16	360	9.0	360
Gypsum lath, plain or perforated	3/8 in. lath and 1/2 in. plaster	0.092 in. by 1-1/8 in. long, 19/64 in. head, gypsum wallboard blued nail or 0.120 in. nail by 1-1/4 in. long, min. 3/8 in. head	5	16	200	5.5	200

0.229 in. by 3 in. by 3 in. in size. The hole in the plate washer shall be permitted to be diagonally slotted with a width of up to 3/16 in. larger than the bolt diameter and a slot length not to exceed 1-3/4 in., provided a standard cut washer (see Appendix A) is placed between the plate washer and the nut. The plate washer shall extend to within 1/2 in. of the edge of the bottom plate on the side(s) with sheathing or other material with nominal unit shear capacity greater than 400 plf for wind or seismic.

Exception: Standard cut washers shall be permitted to be used where anchor bolts are designed to resist shear only and the following requirements are met:

- a) The shear wall is designed in accordance with provisions of 4.3.5.1 with required uplift anchorage at shear wall ends sized to resist overturning neglecting dead load stabilizing moment.
- b) Shear wall aspect ratio, h/b , does not exceed 2:1.
- c) The nominal unit shear capacity of the shear wall does not exceed 980 plf for seismic or 1370 plf for wind.

The 1/2 in. distance from the washer edge to the sheathed edge (Fig. 4) limits potential for cross grain bending but is not required for low strength sheathing materials because bottom plate failure is not the failure limit state. For low strength materials, failure mechanisms include tear-out and slotting (e.g., gypsum wallboard) of the sheathing as well as fastener head pull-through. An exception to the plate washer requirement is provided based on testing and is applicable for walls having an aspect ratio less than 2:1, nominal shear for seismic not exceeding 980 plf (comparable to 7/16 in. OSB with 8d nails at 3 in. o.c. at panel edges) and where hold downs are sized to resist total overturning neglecting dead load stabilizing moment.

Fiberboard Aspect Ratio

An increased aspect ratio for structural fiberboard shear walls has been incorporated in Table 4.3.4 (Table 4) based on strength and stiffness determined from cyclic testing. A maximum aspect ratio of 3.5:1 is permitted but adjustment factors accounting for reduced strength and stiffness are applicable where the aspect ratio is greater than 1.0. For seismic design, the aspect ratio reduction factor is based on analysis of reduced stiffness of high aspect ratio walls relative to the reference case (aspect ratio 1:1) and results in a maximum reduction factor of 0.36 at a 3.5:1 aspect ratio. For wind design, the strength reduction factor accounts for observed reduction in peak unit shear strength as aspect ratio increases relative to the reference case and results in a reduction factor of 0.78 at a 3.5:1 aspect ratio.

Related revisions based on the testing program include an increase in the required panel edge distance for nailing at top and bottom plates and removal of 8d common nails as a permitted fastener for attachment of structural fiberboard sheathing. Specific provisions of the SDPWS read as follows:

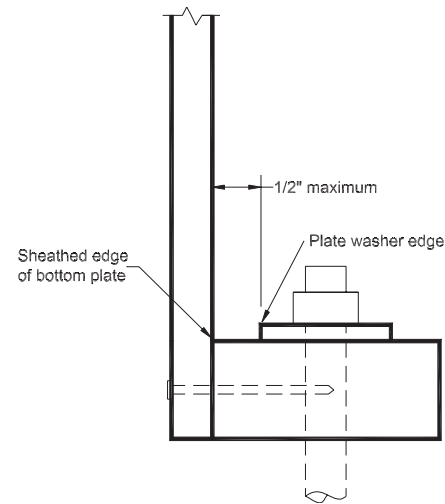

Figure 4.—Distance for plate washer edge to sheathed edge.

Table 4.—Excerpt from SDPWS Table 4.3.4.—Maximum shear wall aspect ratios.

Shear wall sheathing type	Maximum h/b_s ratio
....	
Fiberboard – structural	3.5:1 ³

³ For design to resist seismic forces, the shear wall aspect ratio shall not exceed 1:1 unless the nominal unit shear capacity is multiplied by the Aspect Ratio Factor (Seismic) = $0.1 + 0.9 b_s/h$. The value of the Aspect Ratio Factor (Seismic) shall not be greater than 1.0. For design to resist wind forces, the shear wall aspect ratio shall not exceed 1:1 unless the nominal unit shear capacity is multiplied by the Aspect Ratio Factor (Wind) = $1.09 - 0.09 h/b_s$. The value of the Aspect Ratio Factor (Wind) shall not be greater than 1.0.

4.3.7.4 Fiberboard shear walls 2. Nails shall be located at least 3/4 in. from edges of panels at top and bottom plates and at least 3/8 in. from all other edges of panels. Maximum nail spacing at panel edges shall be 4 in. on center.

Format of Diaphragm and Shear Wall Tables for Wood Structural Panels (OSB and Plywood)

A revised format of diaphragm and shear wall tables incorporates apparent shear stiffness, G_a , for OSB and plywood in the same tables. Previously, Appendix tables were used to provide tabulated values of apparent shear stiffness for plywood.

Reference Documents

References to product standards have been updated. Addition and update of product standards are as follows:

Product Standards Added

- ANSI/CPA A135.6, *Hardboard Siding*, Composite Panel Association, Gaithersburg, MD, 2006. (Replaces AHA A135.4-95 and AHA A135.5-95)
- ASTM C 1396/C 1396M-06a, *Standard Specification for Gypsum Board*, ASTM, West Conshohocken, PA, 2006. (Replaces ASTM C 36/C 36M-01, ASTM C 37/C 37M-01,

ASTM C 79/C 79M-01, ASTM C 588/C 588M-01, ASTM C 630/C 630M-01)

Product Standards Updated

- *ANSI A208.1-99, Particleboard*, ANSI, New York, NY, 1999.
- *PS 1-07 Structural Plywood*, United States Department of Commerce, National Institute of Standards and Technology, Gaithersburg, MD, 2007.
- *PS 2-04 Performance Standard for Wood-Based Structural Use Panels*, United States Department of Commerce, National Institute of Standards and Technology, Gaithersburg, MD, 2004.

2008 SDPWS Commentary

Updates to the *SDPWS Commentary* based on input from users and new information considered in development of the 2008 SDPWS standard will be available in early 2009.

Building Codes and Standards

The 2008 SDPWS has been approved as a reference document in the 2009 *International Building Code* and has been submitted for adoption as a reference document in *ASCE 7-11 Minimum Design Loads for Buildings and Other Structures*.

Conclusion

AWC's 2008 SDPWS was approved August 4, 2008 as an American National Standard. SDPWS covers materials, design, and construction of wood members, fasteners, and assemblies to resist wind and seismic forces.

As an update to the 2005 SDPWS standard, several notable new provisions of the 2008 SDPWS standard provide new design options for wood construction to resist forces from wind or seismic coupled with limitations on the use of new design options. Examples include new criteria for wood structural panels designed to resist combined shear and uplift from wind, addition of provisions for unblocked shear walls, and an increased aspect ratio for structural fiberboard shear walls.

The 2008 SDPWS standard is available to download free at www.awc.org.

Philip Line, PE., Senior Manager, Engineering Research; Bradford K. Douglas, PE., Senior Director, Engineering; Peter Mazikins, PEng., Senior Manager, Engineering Standards, American Forest & Paper Association/American Wood Council, Washington, DC.