

PART XII: NAILS AND SPIKES

12.1-GENERAL

12.1.1-General Provisions

Provisions for common steel wire nails and spikes have been part of the Specification since the 1944 edition. Threaded hardened-steel nails and box nails were added in the 1962 edition and the 1977 edition, respectively.

Differences in Nail Types. For the same pennyweight classification and length, round spikes have a larger shank diameter than common nails and may have either a chisel point and countersunk oval head or a diamond point with a flat head. Spikes over $60d$ are generally specified by length (57,70).

Threaded or deformed shank hardened-steel nails include both ring or annularly threaded and helically threaded nails. For equivalent pennyweight and length, hardened-steel nails have a smaller shank diameter than common nails for pennyweights of $8d$ and larger. The head diameter of $20d$ and smaller hardened-steel nails is larger than that of the corresponding common nail but is smaller for larger sizes (those over 4 inches in length) (70).

Box nails have a smaller shank diameter than common nails of equivalent pennyweight. The head diameter of box nails is larger than that of common nails for sizes less than $10d$, is the same for the $10d$ to $16d$ sizes and is smaller for sizes $20d$ and larger (70).

Nail Specifications. The requirement that nails intended for use in engineering construction be specified by length and diameter was introduced in the 1986 edition. The specification also should include head diameter if the nail is produced in more than one head diameter for the same length and shank diameter; and thread type or head and point type if other than common or box nails are to be used (70).

General Construction. Most nailed joints in light frame wood construction are not engineered but are made in accordance with standard practices that have been established from many years of field experience (126). Such practices are expressed in terms of nailing schedules which give the number, size and type of nail, and the direction of driving (e.g. face nailing, toenailing) to be used for different connections. For example, use of three $8d$ toenails to attach joists to a sill plate; and use of four $8d$ toenails or two $16d$ face or end

nails to attach studs to bottom and top plates are standard practices accepted by most building codes.

The provision recognizing the use of standard nailing schedules (126) in lieu of designing joints for specific loads was first introduced in the 1982 edition.

12.1.2-Quality of Nails and Spikes

12.1.2.1 Standard diameters for the various types of nails and spikes were tabulated in previous editions of the Specification. In the 1991 edition, Federal Specification FF-N-105B (70) is referenced as the basic dimensional standard. Paragraphs 3.6.5, 3.6.11.2, 3.16.9 and 3.9-Style 3 of this Federal Specification cover steel wire box nails, steel wire common nails, pallet or threaded hardened steel nails, and round steel wire spikes, respectively. Nails or spikes outside the diameter and length classes covered in the Federal Specification for each type may be available. Provisions of the 1991 edition may be applied to such nails or spikes when the applicable diameters and lengths are specified and used to determine design values.

The nail provisions of the 1991 edition also apply to common wire nails made of copper or aluminum alloy conforming to the sizes given for such metals in Federal Specification FF-N-105B. It is the designer's responsibility to use appropriate bending yield strengths for such metals when determining lateral design values in accordance with 12.3 and to assure the tensile, bearing and shear strengths of the fastener are adequate to resist loads being transferred through the fastener to the wood members in the joint (see 7.2.3 of Specification).

12.1.2.3 The requirements for threaded hardened-steel nails have remain unchanged since the 1962 edition.

12.1.3-Fabrication and Assembly

12.1.3.1 A limitation on the size of prebored holes for nails and spikes was first introduced in the 1952 edition. Such holes were limited to 75 percent of the diameter of the fastener. In the 1962 edition, the limitation was changed to 90 percent for Group I species, those having a specific gravity of 0.62 or larger; and 75 percent for Group II, III and IV species, those having a specific gravity of 0.59 or less. These provisions were carried forward unchanged through the 1986 edition. The limitation on prebored nail and spike holes remains the same in the 1991 edition except that

the separation between the most dense species and other species is defined in terms of specific gravity rather than fastener species groups. The latter are no longer used for connection design in the 1991 edition.

12.1.3.2 Toenailing procedures consisting of slant driving of nails at a 30° angle from the face of the attached member with an end distance (distance between end of side member and initial point of entry) of one-third the nail length have been part of the Specification since the 1952 edition. Based on lateral and withdrawal tests of nailed joints in frame wall construction (62,160), the toenail factors of 12.2.3 and 12.3.7 presume use of these driving procedures and the absence of excessive splitting. If such splitting does occur, a smaller nail should be used.

12.2-WITHDRAWAL DESIGN VALUES

12.2.1-Withdrawal from Side Grain

Background

Withdrawal design values for nails and spikes are based on the equation

$$W = 1380 G^{5/2} D \quad (\text{C12.2-1})$$

where:

- W = nail or spike withdrawal design value per inch of penetration in member holding point, lbs
- G = specific gravity of member holding point based on oven dry weight and volume
- D = shank diameter of the nail or spike, in.

Equation C12.2-1 was based on early research (56,64) and has been used to establish nail and spike withdrawal design values since the 1944 edition. Withdrawal design values obtained from the equation represented about one-fifth average ultimate test values expressed on the same unit penetration basis. The one-fifth factor included the originally recommended one-sixth factor on ultimate load (57) increased 20 percent as part of the World War II emergency adjustment in wood design values. The 1.2 factor was subsequently codified as 10 percent for the change from permanent to normal loading and 10 percent for experience (see Commentary for 2.3.2).

Both Equation C12.2-1 and resultant tabulated withdrawal design values for common wire nails and spikes by species were presented in the 1944 and 1948 editions. In 1950, tabulated withdrawal design values began to be shown in terms of specific gravity rather than species. In the 1962 edition, Equation C12.2-1

was dropped from the Specification in favor of the withdrawal design value table alone.

Also in the 1962 edition, provisions for assigning withdrawal design values to threaded hardened nails were introduced. Such nails were assigned the same withdrawal design values as those for common wire nails of the same pennyweight class. However, the procedure was modified in the 1968 edition to account for the fact that although the diameter of common wire nails increases as pennyweight class increases from 20d to 60d, the diameters of threaded hardened nails in this range and larger do not. The diameter of 30d, 40d, 50d and 60d threaded hardened nails is the same as that (0.177 inches) for the 20d nail of this type, and the diameter for 80d and 90d threaded hardened nails was the same as that (0.207 inches) for the 70d size. To adjust for these differences, the 20d to 60d threaded hardened nails were assigned the same withdrawal design value as that for 20d common nails having a diameter of 0.192 inches. The 70d to 90d threaded hardened nails were assigned the same withdrawal design value as that for a common nail having a diameter which was in the same ratio to the 70d threaded hardened nail diameter of 0.207 as the common to threaded nail diameter ratio for 20d nails, or 0.192/0.177. This equivalent diameter is 0.225 inches, the diameter of a 40d common nail. For 20d and smaller pennyweights of threaded hardened nails, the same withdrawal design values as those for the equivalent size common nails were used as in the previous edition.

Withdrawal design values for box nails based on Equation C12.2-1 were introduced in the 1977 edition. The foregoing procedures for establishing withdrawal design values for nails and spikes were carried forward unchanged through the 1986 edition.

1991 Edition

Withdrawal design values tabulated in the 1991 edition are based on the same methodology used in the previous edition. However, withdrawal design values in Table 12.2A of the 1991 edition for common nails, spikes and box nails are consolidated in one part of the table under a common set of shank diameters, rather than being listed separately. Reference should be made to Tables 12.3A, 12.3B, and 12.3D to determine which diameters apply to box nails, common nails and spikes. Withdrawal design values for threaded hardened nails are given in a separate portion of Table 12.2A because of their different basis.

Special note is to be made of the wet service factor (C_M) of 0.25 that is applicable to withdrawal design

values for smooth-shank nails inserted in partially seasoned or wet wood that will season in service or installed in dry wood that will be subject to wetting and drying in service (see 7.3.3).

Clinching. It is to be noted that the withdrawal resistance of smooth-shank nails can be significantly increased by clinching (35). Increases in withdrawal resistance of 45 to 170 percent due to clinching have been reported when nails are tested soon after driving. When installed in unseasoned or partially seasoned wood and tested after seasoning, increases of 250 to 460 percent as a result of clinching have been observed. Clinching across the grain was found to give 20 percent higher withdrawal design values than clinching along the grain. When a greater assurance of a given level of withdrawal resistance is needed with smooth-shank nails, clinching should be considered.

12.2.2-Withdrawal from End Grain

Reduction of withdrawal design values up to 50 percent have been reported for nails driven in end grain surfaces (radial-tangential plane) as compared to side grain (radial-longitudinal or tangential-longitudinal planes) surfaces (57,160). When coupled with the effects of seasoning in service after fabrication, such reductions are considered too great for reliable design. It is considered to be on this basis that loading of nails and spikes in withdrawal from end grain has been prohibited in the Specification since the 1944 edition.

12.2.3-Toe-Nail Factor, C_{tn}

The 0.67 adjustment of withdrawal design values for toenailing has been a provision of the Specification since the 1951 edition. The adjustment is based on the results of joint tests comparing slant driving and straight driving (57) and of typical toenailed and end nailed joints used in frame wall construction (160) where the attached member is pulled directly away from the main member. It is applicable to joints fabricated at all levels of seasoning. This includes multiple nail joints fabricated of unseasoned wood and then loaded after seasoning (57,66,160). When properly driven (see Commentary for 12.1.3.2), toenailing with cross slant driving can produce stronger joints than end or face nailing. For example, a stud to plate joint made of four $8d$ toenails was reported to be stronger than the same joint made with two $16d$ end nails (62,160).

Where toenailing is employed, the depth of penetration of the nail in the member holding the point may be taken as the actual length of nail in the member as shown in Figure C12.3-1, or (see 12.1.3.2)

$$p_w = L_n - \frac{L_n/3}{\cos 30^\circ} \quad (C12.2-2)$$

$$= 0.615 L_n$$

where:

- p_w = penetration of nail in member holding point, in.
- L_n = length of nail, in.

12.3-LATERAL DESIGN VALUES

12.3.1-Wood-to-Wood Connections

Background

From the 1944 through the 1986 editions, lateral design values for nails and spikes loaded at any angle to grain were based on the equation

$$Z = K_L D^{3/2} \quad (C12.3-1)$$

where:

- Z = nominal nail or spike lateral design value, lbs
- K_L = species group constant based on specific gravity (G) of wood members
 - = 2040 Group I $G = 0.62 - 0.75$
 - = 1650 Group II $G = 0.51 - 0.55$
 - = 1350 Group III $G = 0.42 - 0.49$
 - = 1080 Group IV $G = 0.31 - 0.41$
- D = nail or spike shank diameter, in.

Equation C12.3-1 was based on early nail tests (57,59) and assumed certain minimum penetrations of the fastener in the main member (see Commentary for 12.3.4). Values assigned to the constant K_L gave lateral design values that were approximately 75 percent of proportional limit test values. These values included the originally recommended adjustment of 1.6 (57) increased 20 percent as part of the World War II emergency increase in wood design values. The latter adjustment was subsequently codified as a 10 percent increase for the change from permanent to normal loading and 10 percent for experience (see Commentary for 2.3.2). Nail lateral design values of 75 percent of proportional limit values are about one-fifth maximum test values for softwoods and about one-ninth maximum test values for hardwoods (57).

From the 1944 through the 1960 editions, the individual group equations were presented in the Specification along with the list of species to which each applied. Beginning with the 1950 edition, tabulated nail and spike lateral design values based on the

equations for each group were included in the Specification. Presentation of the lateral design value equations was then discontinued beginning with the 1962 edition. In the 1960 and earlier editions, a nail fastener group between Groups II and III was included in the specification for intermediate density hardwood species. This intermediate group also was dropped beginning with the 1962 edition as most of the included species were of little commercial importance.

Prior to the 1971 edition, grain type and other features than specific gravity were taken into account in classifying species into fastener groups. This was evidenced by some species with the same specific gravities being classified in Group III and others in Group IV (57,62). Beginning with the 1971 edition, specific gravity was used as the sole criterion for assignment of species for nail lateral design value constants. The specific gravity class limits shown in the legend for Equation C12.3-1 were used to classify species from 1971 through the 1986 edition.

Provisions for establishing lateral design values for threaded hardened nails were introduced in the 1962 edition. These nails were assigned the same lateral design values as those for common nails of the same pennyweight class. The smaller diameter of the threaded hardened nails compared to the common nails was considered to be offset by the higher bending strength of the former. In the 1968 edition, assignments for $30d$ and larger threaded hardened nails were reduced to account for the fact that the diameters of the $30d$ to $60d$ pennyweight sizes were the same as the diameter for the $20d$ nail of this type, and the diameters of the $80d$ and $90d$ sizes were the same as the $70d$ size. Under this change, the $20d$ to $60d$ threaded hardened nails were assigned the same lateral design value as that for the $20d$ common nail and the $70d$ to $90d$ threaded hardened nails were assigned the same lateral design value as that for the $40d$ common nail. The ratio of the diameter of the $70d$ threaded hardened nail to that of the $40d$ common nail is the same as the ratio of the $20d$ threaded hardened nail to that of the $20d$ common nail (see Commentary for 12.2.1 - Background). These procedures for establishing lateral design values for threaded hardened nails were continued through the 1986 edition.

Lateral design values for box nails based on Equation C12.3-1 were first introduced in the 1977 edition.

It is to be noted that lateral design values tabulated in the 1986 and earlier editions of the Specification were not considered associated with a specific deformation level. However, it was reported that the propor-

tional limit of a nailed joint could be assumed to be associated with a slip of approximately 0.015 inches (65,160). As Equation C12.3-1 is considered to give average lateral design values that are about 75 percent of average proportional limit test values, the lateral design values tabulated in previous editions would index to an average initial slip of 0.011 inches. This deformation level excludes the effects of any creep occurring under design loads.

1991 Edition

Nail and spike lateral design values in the 1991 edition are based on application of the yield limit model (see Commentary for 7.2.1 and 8.2.1) which also has been used to establish the lateral design values for bolts, lag screws and wood screws. The yield mode equations given in 12.3.1 for nails and spikes in single shear have been developed and verified in recent research (27,28). The equations provide for four modes of yielding: bearing in the side member being attached (Mode I_s), development of a plastic hinge in the side member (Mode III_m), development of a plastic hinge in the main member (Mode III_s), and development of plastic hinges in both main and side members (Mode IV). The lowest lateral design value, Z , obtained from the four equations is taken as the basic lateral design value for the particular connection being evaluated. It is to be noted that the Mode III_m equation, unlike the other nail yield mode equations and those for other dowel type fasteners, includes a term to account for the length or penetration of the nail in the main member. All equations, however, require a minimum penetration of six diameters in the main member.

The K_D term in the denominator of each yield mode equation represent factors to reduce yield mode equation values based on a 5 percent diameter offset dowel bearing strength to the general level of the proportional limit based lateral design values tabulated in previous editions of the Specification. Values of K_D vary depending upon the shank diameter, D , of the nail or spike, as shown below.

$$\begin{array}{ll} D \leq 0.17 & K_D = 2.2 \\ 0.17 < D < 0.25 & K_D = 10(D) + 0.5 \\ D \geq 0.25 & K_D = 3.0 \end{array}$$

The 2.2 factor for fasteners 0.17 inches or less in diameter is based on a comparison of yield mode lateral design values with nail lateral design values published in the 1986 edition for joints made with $8d$ and $16d$ nails in each of two species for a range of side member thicknesses (117). The 0.17 diameter limit covers all standard box nail sizes (up to $40d$) and common and threaded hardened nails up to $16d$. Most

spikes fall in the larger diameter classes. Because side member thickness is a variable in the yield mode equations but was not a factor in developing lateral design values given in previous editions, the K_D value of 2.2 gives lower lateral design values for joints made with the thinnest side members (5/16 inch) than those previously tabulated for equivalent species and nail size, but larger lateral design values for joints made with thicker side members (1-1/2 inch). In addition to having substantially higher lateral design values than those previously given in the Specification, nailed and spiked joints made with the thicker side members also had significantly higher lateral design values than lag screw and wood screw joints made with the same diameter fastener and side member thickness when the K_D value of 2.2 was used in the nail yield equations for these combinations. As the larger diameter nails and spikes are used with the thicker side members, the foregoing inconsistencies were addressed by increasing the K_D factor for nail and spike diameters of 0.25 inches or more from 2.2 to 3.0, limiting the 2.2 factor to 0.17 diameters and less, and use of a linear transition ($K_D = 10d + 0.5$) for intermediate diameters. These K_D factor assignments are the same as those used with the yield mode equations for wood screws (see 11.3.1).

No adjustment of nail or spike yield mode equation values are made for varying angles of load to grain. This is a continuation of provisions in previous editions of the Specification which assigned the same nail or spike lateral design values to both parallel and perpendicular to grain loading conditions.

The nail and spike yield mode equations are entered with the fastener diameter, the side member thickness, the dowel bearing strengths of the main and side members (F_{em} and F_{es}), and the bending yield strength of the fastener (F_{yb}). Dowel bearing strengths for all species combinations are listed in Table 12A. These dowel bearing strength values are based on the same specific gravity equation used to establish dowel bearing strengths for wood screws (see Commentary for 11.3.1 - 1991 Edition and Equation C11.3-2). The equation is based on research which involved bearing tests of nails 12d to 40d in size and which showed that diameter was not a significant independent variable with specific gravity (203).

The bending yield strength of the nail or spike, F_{yb} , may be specified by the designer or the values given in the footnotes in Tables 12.3A, 12.3B, 12.3C or 12.3D may be used (see Appendix I). The footnote values are based on the results of tests of common wire nails which showed that bending yield strength tends to

increase as diameter decreases (106). The regression of test values from which nail bending yield strength values were estimated is given below.

$$F_{yb} = 130.4 - 214D \quad (\text{C12.3-2})$$

where:

$$F_{yb} = \text{bending yield strength of steel based on 5 percent diameter offset, 1000 psi}$$

$$D = \text{nail diameter, in.}$$

The increase in yield strength associated with the decrease in diameter is attributed to the work hardening of the steel as it is formed into progressively smaller diameters (106).

Bending yield strength values for hardened steel nails given in the footnote of Tables 12.3C are based on bending yield strength values for common nails of equivalent diameter increased approximately 30 percent (see Appendix I).

Tabulated Wood-to-Wood Lateral Design Values. Lateral design values for single shear connections made with 1/2 to 1-1/2 inch thick side members for each of the major individual species combinations are given in Tables 12.3A to 12.3D. Tables A, B, C and D give lateral design values for 6d to 40d box nails, 6d to 60d common nails, 6d to 90d threaded hardened nails and 10d to 3/8d spikes, respectively. Tabulated lateral design values apply to joints made with side and main members of the same thickness. Where different species are used, lateral design values for the species with the lowest specific gravity may be applied. However, in certain designs, use of the tabulated lateral design values for the lowest specific gravity wood in the joint may be considered overly conservative. In such cases, determining allowable joint lateral design values directly from the yield mode equations may prove beneficial. The difference between tabulated lateral design values and yield mode lateral design values for mixed species joints are illustrated in the nail examples presented in Example C12.3-1.

The effect of side member thickness on nail lateral design values is not linear. Tabular lateral design values should not be extrapolated to obtain lateral design values for side member thicknesses larger than the maximum thickness listed in the tables (see Example C12.3-1). For joints made of species other than those tabulated, lateral design values for a listed species combinations with a lower specific gravity than that for the species being used, as determined from Table 12A, may be applied. With the highest density hardwoods,

Example C12.1-1

Yield mode lateral design values for wood-to-wood single shear nailed connections:

Single and mixed species joints of southern pine and spruce-pine-fir made with 8d common nails in side member thicknesses of 3/8, 1/2 and 5/8 inches and with 60d common nails in side member thicknesses of 1/2, 1-1/2, and 2-1/2 inches

- F_{em}, F_{es} = 5550 psi southern pine (SP)
- = 3350 psi spruce-pine-fir (SPF)
- F_{yb} = 100,000 psi 8d
- = 70,000 psi 60d
- D = 0.131 8d
- = 0.263 60d
- K_D = 2.2 8d
- = 3.0 60d
- p = nail length - side member thickness

Nail Penny- Weight	Side Member Thickness in.	Species		Yield Mode Design Values, lbs			
				Main		Side	
				ZI,	ZIII _m	ZIII,	ZIV
8d	3/8	SP	SP	124	242	<u>78</u>	106
		SPF	SP	124	160	<u>69</u>	92
		SP	SPF	75	219	<u>65</u>	92
		SPF	SPF	75	149	<u>59</u>	82
	1/2	SP	SP	165	229	<u>85</u>	106
		SPF	SP	165	152	<u>76</u>	92
		SP	SPF	100	207	<u>68</u>	92
		SPF	SPF	100	141	<u>61</u>	82
	5/8	SP	SP	207	216	<u>94</u>	106
		SPF	SP	207	144	<u>84</u>	92
		SP	SPF	125	195	<u>72</u>	92
		SPF	SPF	125	134	<u>65</u>	82
60d	1/2	SP	SP	243	905	<u>188</u>	262
		SPF	SP	243	593	<u>165</u>	228
		SP	SPF	<u>147</u>	821	161	228
		SPF	SPF	147	551	<u>144</u>	204
	1-1/2	SP	SP	730	745	288	<u>262</u>
		SPF	SP	730	491	260	<u>228</u>
		SP	SPF	441	676	<u>207</u>	228
		SPF	SPF	441	456	<u>191</u>	204
	2-1/2	SP	SP	1216	588	433	<u>262</u>
		SPF	SP	1216	391	392	<u>228</u>
		SP	SPF	734	533	294	<u>228</u>
		SPF	SPF	734	363	272	<u>204</u>

this will result in significant underestimation of joint capacity.

Comparison of 1991 and Earlier Edition Lateral Design Values. Differences in lateral design values for single shear nailed connections in the 1991 and 1986 editions resulting from the change to the yield limit model and the use of individual species rather than fastener group values is illustrated in Table C12.3-1.

Table C12.3-1 - Comparison of 1991 and 1986 NDS Wood-to-Wood Single Shear Nail Lateral Design Values

Side Member Thick- ness, in.	Nail Penny- Weight	Nail Diam. in.	Nail Lateral Design Value, lbs					
			Southern Pine			Spruce-Pine-Fir		
			1991	1986	Ratio	1991	1986	Ratio
Box Nails:								
1/2	8d	0.113	67	63	1.06	47	51	0.92
	20d	0.148	101	94	1.07	73	77	0.95
3/4	8d	0.113	79	63	1.25	57	51	1.12
	20d	0.148	121	94	1.29	83	77	1.08
Common Nails:								
1/2	8d	0.131	85	78	1.09	61	64	0.95
	20d	0.192	137	139	0.99	103	114	0.90
1-1/2	20d	0.192	185	139	1.33	144	114	1.26
	60d	0.263	262	223	1.17	191	182	1.05
Threaded Hardened Nails:								
1/2	8d	0.120	80	78	1.03	58	64	0.91
	20d	0.177	147	139	1.06	111	114	0.97
1-1/2	16d	0.148	145	108	1.34	113	88	1.28
	70d	0.207	227	176	1.30	171	144	1.19
Spikes:								
1/2	20d	0.225	162	176	0.92	123	144	0.85
	60d	0.283	201	248	0.81	155	203	0.76
1-1/2	40d	0.263	262	223	1.17	191	182	1.05
	3/8	0.375	428	379	1.13	290	310	1.07

The consistently higher 1991/1986 lateral design value ratios for the 3/4 and 1-1/2 inch side member thicknesses relative to the ratios for the 1/2 inch side member thickness reflect the use of side member thickness as a variable in the yield mode equations whereas previous lateral design values were independent of member thickness. The generally lower lateral design value ratios for the fasteners with diameters over 0.25 inches relative to those with diameters less than 0.17 inches represents the effect of the larger K_D factor (3.0) used in the yield mode equations for the former as compared to the factor (2.2) used with the latter.

For the joint configurations compared, the averages of the 1991/1986 lateral design value ratios were 1.13 for southern pine and 1.02 for spruce-pine-fir. This difference reflects the fact that southern pine was at the upper limit of its 1986 fastener group (specific gravity) class whereas spruce-pine-fir was near the lower limit of its class. By basing the dowel bearing strength used in the yield mode equations on the specific gravity of each species combination rather than basing lateral design values on specific gravity groups, the 1991 provisions tie nail lateral design values more closely to the performance capabilities of each species combination than was previously the case.

12.3.2-Wood-to-Metal Connections

12.3.2.1 From the 1944 through the 1986 edition, lateral design values for nails and spikes were increased 25 percent when metal rather than wood side plates were used (57). This is the same metal side plate adjustment previously used with wood screws over the same period and with bolts prior to the 1982 edition. Recent test results indicated the 25 percent increase for nailed wood-to-metal joints was conservative (165). In the 1991 edition, the effect of the metal side plates is accounted for directly by entering the dowel bearing strength, F_{cs} , and the thickness of the metal side plate in the yield mode equations of 12.3.1. Only yield Modes III_m, III_s and IV are considered. The Mode I_s equation for bearing in the side member is not used as this property is considered separately in the design of metal parts (see 12.3.2.2 and Commentary for 7.2.3).

Tables 12.3E, 12.3F, 12.3G and 12.3H give lateral design values for joints made with steel box nails, common nails, threaded hardened nails and spikes, respectively, and steel side members ranging from 0.036 inches (20 gage) to 0.239 inches (3 gage) in thickness. Tabulated lateral design values for all side plate thicknesses are based on a dowel bearing strength of 45,000 psi applicable to ASTM A446 Grade A galvanized steel. The same nail and spike bending yield strengths, F_{yb} , used to develop the wood-to-wood joint lateral design values in Tables 12.3A - 12.3D were used to develop the tabulated lateral design values for joints made with steel side plates.

Comparison of 1991 and Earlier Edition Lateral Design Values. Differences between 1991 and 1986 lateral design values for joints made with steel side plates and common nails are illustrated in Table C12.3-2.

The average of the 1991/1986 lateral design value ratios for the two plate thicknesses and three nail sizes compared in the table are 1.00 and 0.98 for the

Table C12.3-2 - Comparison of 1991 and 1986 NDS Wood-to-Metal Single Shear Nail Lateral Design Values

Steel Plate Thickness, in.	Nail Penny-Weight	Nail Diam. in.	Nail Lateral Design Value, lbs					
			Southern Pine			Spruce-Pine-Fir		
			1991	1986	Ratio	1991	1986	Ratio
Box Nails:								
0.075	8d	0.113	78	79	0.99	63	64	0.98
	20d	0.148	124	118	1.05	99	96	1.03
0.134	8d	0.113	90	79	1.14	74	64	1.16
	20d	0.148	137	118	1.16	111	96	1.16
Common Nails:								
0.075	8d	0.131	103	98	1.05	83	80	1.04
	20d	0.192	176	174	1.01	141	142	0.99
	60d	0.263	248	279	0.89	198	228	0.87
0.134	8d	0.131	115	98	1.17	94	80	1.18
	20d	0.192	188	174	1.08	152	142	1.07
	60d	0.263	256	279	0.92	206	228	0.90
Spikes:								
0.075	16d	0.207	192	194	0.99	154	159	0.97
	60d	0.283	266	310	0.86	212	254	0.83
	3/8	0.375	404	474	0.85	321	388	0.83
0.134	16d	0.207	203	194	1.05	163	159	1.03
	60d	0.283	274	310	0.88	221	254	0.87
	3/8	0.375	411	474	0.87	330	388	0.85

southern pine and spruce-pine-fir joints, respectively. Because the variation in thickness of typical steel side plates is small (0.036 to 0.239) relative to the variation in thickness of wood side members (1/2 to 1-1/2), plate thickness has a smaller effect on 1991 joint lateral design values than does wood side member thickness when both are compared to 1986 lateral design values. As with the wood-to-wood joints, the lower 1991/1986 lateral design value ratios for the larger diameter nails reflect the larger adjustment factor, K_D , used with these fasteners compared to that used for the smaller diameter fasteners.

12.3.2.2 (See Commentary for 7.2.3)

12.3.2.3 Design values for joist hangers, tie downs and other similar products that involve wood-to-metal nailed joints often are established by testing connections made with the installed product rather than by use of the provisions of the Specification. As noted in the Commentary for 12.3.1, lateral design values tabulated in the 1991 and earlier editions are derived from nominal proportional limit level values and are about one-fifth short term ultimate test values. Design values for proprietary products such as hangers and other

connecting devices may be based on proportional limit test values or on maximum test values. It is the responsibility of the designer to determine the appropriateness of the procedures used to establish such design values, including the adequacy of reductions for load duration and variability, and the appropriateness of applying other adjustments given in the Specification to those design values (see Commentary for 1.1.1.4 and 7.1.1.4).

12.3.3-Double Shear Wood-to-Wood Connections

An increase in lateral design values for connections in double shear where the nail fully penetrated all members of a three-member joint was introduced in the 1960 edition of the Specification. An increase of one-third was allowed when each side member was not less than one-third the thickness of the main or center member and two-thirds when the thicknesses of the side members was equal to the thickness of the main member. Interpolation for intermediate side member thicknesses subsequently was provided for in the 1962 edition. In the 1982 edition, a clarifying provision was added to the Specification which applied the penetration requirements for single shear joints to the center member of three member joints. These provisions covering the design of nailed joints in double shear were carried forward unchanged to the 1986 edition.

In the 1968 edition, a separate adjustment for three member joints made with clinched nails was introduced. This new provision allowed a doubling of the single shear lateral design value for joints made with $12d$ or smaller nails if the thickness of the side members was $3/8$ inch or larger and the nails extended beyond the side member by at least three diameters and were clinched. This addition was based on tests of single shear and clinched and unclinched double shear joints made with plywood side members (108). In the 1971 edition, the clinching requirement for three member joints made with threaded hardened nails was waived if the side member, nail size and nail length requirements for doubling of single shear lateral design values were met. This change, which reflected the difficulty of clinching this type of fastener, was based on tests of single and double shear joints made with unclinched threaded hardened nails (171). The provisions allowing the doubling of single shear lateral design values for certain nailed joints in double shear were also carried forward through the 1986 edition.

In the 1991 edition, a doubling of the lateral design value for single shear joints is recognized for any three member wood-to-wood connection in which the thickness of the center or main member is greater than six times the nail or spike diameter. The provision is

based on recent research which shows that the total yield mode load capacity of a three member joint is equivalent to twice that of a comparable two member or single shear joint (28). The six times fastener diameter requirement on the thickness of the center member in a three member joint is related to the requirement of 12.3.4 that the minimum nail or spike penetration into the main member be at least six times the fastener diameter.

Unlike previous editions, the 1991 provisions for three member wood-to-wood joints have no requirements on side member thickness to qualify for an increase in the single shear lateral design value if the third member meets the penetration requirements of 12.3.4. This reflects the fact that side member thickness is a variable in the yield mode equations that are used to establish lateral design values in the 1991 edition. Application of the $12D$ penetration requirement of 12.3.4 to the third member of a three member joint would exclude use of certain panel side member materials which qualified for the three member joint increase in previous editions. To provide for such applications, the clinched nail provisions of earlier editions are used as an exception to the 12.3.4 penetration requirements. Under this exception, three member joints made with $12d$ or smaller size nails and $3/8$ inch or thicker side members qualify for a doubling of the applicable single shear lateral design value when the nail extends at least three diameters beyond the side member and are clinched. The waiver of the clinching requirement for threaded hardened nails that was in previous editions has been dropped as the increased strength of these fasteners relative to common steel wire nails has been accounted for directly in the yield mode equations. Clinching of both common and hardened nails is considered necessary for both to qualify for twice their respective single shear lateral design values.

12.3.4-Penetration Depth Factor, C_d

In the 1960 and earlier editions of the Specification, nails and spikes were required to penetrate the main member a minimum of two-thirds the fastener length for softwoods and one-half the fastener length for hardwoods to qualify for specified lateral design values (57,59). In the 1951 edition, provision was made for use of lesser penetrations if the lateral design value was reduced proportionately; but the minimum penetration was required to be at least one-half the nail length for softwoods and two-fifths the nail length for hardwoods. In the 1960 edition, the minimum penetration allowed for reduced lateral design values was changed to two-fifths the nail length for softwoods and one-third the nail length for hardwoods.

Beginning in the 1962 edition, penetration requirements were changed from a fastener length to a fastener diameter basis and the softwood-hardwood classes were dropped in favor of fastener groups based on specific gravity (see Commentary for 12.3.1 - Background). For full lateral design value, penetration of the fastener in the main member of 10 diameters for Group I species, 11 diameters for Group II species, 13 diameters for Group III species and 14 diameters for Group IV species was required. The minimum penetration allowed for reduced lateral design values was set at one-third the penetrations required for full lateral design values. Based on new recommendations (62), the 1962 penetration provisions represented a relaxation of previous requirements. Expressing penetration requirements in terms of nail diameter rather than nail length made it possible to take into account the different diameters of fasteners that are available for the same pennyweight and length. The 1962 penetration provisions were carried forward unchanged to the 1986 edition.

In the 1991 edition, lateral design values are given by individual species combinations rather than by fastener groups. With this change, the penetration requirement for full lateral design value has been simplified to twelve fastener diameters for all species. The minimum allowed penetration for reduced lateral design value has been changed from 3.3 to 4.7 fastener diameters to 6 diameters for all species. This increase in the minimum penetration requirement, based on consideration of new information available on how nails perform in joints (27), serves to account for the consolidation of the previous four separate group requirements into one and for the higher lateral design values obtained for some configurations from the new yield mode models.

12.3.5-End Grain Factor, C_{eg}

The use of a 0.67 adjustment factor on lateral design values for nails or spikes driven in the end grain has been a provision of the Specification since the 1944 edition. The adjustment is based on early research on joints made with softwood species (57).

12.3.6-Diaphragm Factor, C_{di}

Diaphragms are large, flat structural units acting like a deep relatively thin beam or girder. Horizontal wood diaphragms consist of floor or roof decks acting as webs and lumber or glued laminated timber members acting as the flanges. Such assemblies distribute horizontal forces acting on the flanges to vertical resisting elements (145). Shear walls consisting of wall sheathing materials attached to top and bottom plates

and vertical framing members also are diaphragms. Such shear walls or vertical diaphragms act to transfer loads from horizontal diaphragms down to the supporting foundation (182). The diaphragm factor, C_{di} , applies to both horizontal and vertical diaphragms.

Beginning with the 1960 edition of the Specification, an increase in normal load lateral design values for nails and spikes of 30 percent was recognized when these fasteners were used in diaphragm construction. The increase, which applied in addition to wind and earthquake load duration increases, was based on experience with wood diaphragms on the west coast designed using code approved nail shear values approximately 30 percent larger than those given in the Specification (180,181). The increase also was considered appropriate in view of the fact that the lateral design values provided in the Specification represented approximately 75 percent of joint proportional limit test values (one-fifth of maximum test values) (see Commentary for 12.3.1 - Background) and that structural diaphragms involve use of many nails acting together which was viewed as reducing variability effects.

In the 1977 edition, the provision for increasing lateral design values for nails and spikes used in diaphragm construction by 30 percent was revised to clarify that the adjustment applied only to lateral design values and not to withdrawal design values. The diaphragm adjustment provision was carried forward to the 1986 edition without change.

In the 1991 edition the adjustment for diaphragm use has been reduced to 10 percent in recognition of the change in the load duration adjustments for wind and earthquake loads from 1.33 to 1.6. The 10 percent factor provides for approximately the same effective wind and earthquake design load for diaphragms when used with the new load duration factor (1.6 x 1.1) as did the previous 30 percent factor when used with the previous load duration factor (1.33 x 1.3). If a 1.33 adjustment for wind or earthquake load continues to be used in diaphragm design, the 1.30 C_{di} factor should be applied to nail lateral design values.

12.3.7-Toe-Nail Factor, C_{tn}

The toe nail factor of 0.83 has been an adjustment to nail lateral design values since the 1951 edition. This factor is between the full lateral design value applicable to nails driven perpendicular to grain (side grain) surfaces and the two-thirds of full lateral design value applicable to nails driven in parallel to grain (end grain) surfaces.

For toe nails subject to lateral loads, the depth of penetration of the nail in the member holding the point may be taken as the vertically projected length of nail in the member as shown in Figure C12.3-1, or (see 12.1.3.2)

$$p_L = L_n \cos 30^\circ - L_n/3 \quad (C12.3-3)$$

where:

- p_L = vertical projection of penetration of nail in main member, in.
- L_n = length of nail, in.

For purposes of establishing the single shear lateral design value applicable to a toe nailed joint, the side member thickness shall be taken as the length of the nail in the side member (see Figure C12.3-1) or

$$t_s = L_n/3 \quad (C12.3-4)$$

where:

- t_s = effective side member thickness when toenailing is used, in.

Equation C12.3-4 only applies to nails driven at an angle of approximately 30° to the face of the member being attached and one-third the nail length from the end of that member. The effective side member thickness for nails driven at any angle to the face of the member being attached should not exceed the actual thickness of that member.

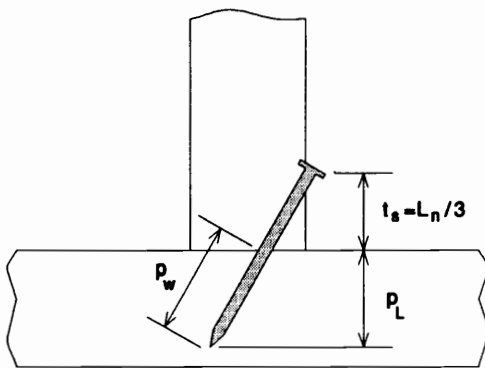

Figure C12.3-1 Effective penetration and side member thickness for toe nails subject to lateral loads.

12.4-PLACEMENT OF NAILS AND SPIKES

12.4.1-Edge Distance, End Distance, Spacing

Absence of splitting has been the performance criterion for placement of nails and spikes since the 1944 edition. Smaller nails can be placed closer to

member ends and edges than larger nails as they are less likely to cause splitting. Where splitting can not be avoided, preboring of nail holes should be used (see 12.1.3.1).

In lieu of specific code requirements for end and edge distance for nails, Table C12.4-1 may be used to establish nailing patterns. Designers should note that specie type, moisture content and grain orientation will affect spacing (pitch) between fasteners in a row.

Table C12.4-1 Nail Minimum Spacing Tables

	Wood Side Members	
	Not	
	Prebored	Prebored
Edge distance	2.5d	2.5d
End distance		
- tension load parallel to grain	15d	10d
- compression load parallel to grain	10d	5d
Spacing (pitch) between fasteners in a row		
- parallel to grain	15d	10d
- perpendicular to grain	10d	5d
Spacing (gage) between rows of fasteners		
- in-line	5d	3d
- staggered	2.5d	2.5d
	Steel Side Members	
	Not	
	Prebored	Prebored
Edge distance	2.5d	2.5d
End distance		
- tension load parallel to grain	10d	5d
- compression load parallel to grain	5d	3d
Spacing (pitch) between fasteners in a row		
- parallel to grain	10d	5d
- perpendicular to grain	5d	2.5d
Spacing (gage) between rows of fasteners		
- in line	3d	2.5d
- staggered	2.5d	2.5d

12.4.2-Multiple Nails or Spikes

Since the 1944 edition, the total design value for a connection made with more than one nail or spike has been determined as the sum of the allowable design values for the individual fasteners. In the 1992 edition, this summation provision is limited to only those nails or spikes in the joint which are of the same size and type (see Commentary for 7.2.2 and 7.1.1.1).