



LRFD

LOAD AND RESISTANCE FACTOR DESIGN

EXAMPLE PROBLEMS FOR WOOD STRUCTURES

**American Forest & Paper Association
Southern Forest Products Association
Wood Truss Council of America**

**In Cooperation with the
International Conference of Building Officials**

The North American wood products industry is dedicated to building a sustainable future

Only one primary building material comes from a renewable resource; cleans the air and water, providing habitat, scenic beauty and recreation as it grows; utilizes nearly 100% of its resource for products; is the lowest of all in energy requirements for its manufacturing; creates fewer air and water emissions than any of its alternatives; and is totally reusable, recyclable and 100% biodegradable: wood. And it has been increasing in US net reserves since 1952, with growth exceeding harvest in the US by more than 30%.

Wood Works!

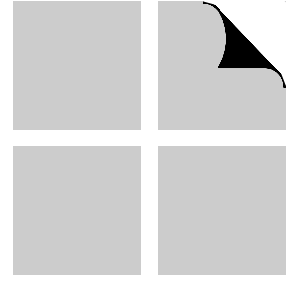

LRFD

LOAD AND RESISTANCE FACTOR DESIGN

**EXAMPLE PROBLEMS
FOR WOOD STRUCTURES**

by

**Steven M. Cramer, Ph.D., P.E.
University of Wisconsin-Madison**

and

**Dan L. Wheat, Ph.D., P.E.
University of Texas at Austin**

PREFACE

This manual is intended to aid instruction in structural design of wood structures using load and resistance factor design. It contains design examples that range from simple to complex and cover many design scenarios. Some problems have been posed as stand-alone problems, but there are several sets in which all examples in the set are associated with a single structure. This may prove useful for those instructors who wish to expose students to slightly more comprehensive problems. Problem sets may be broken into parts and assigned as individual problems.

The *1996 Load and Resistance Factor Design Manual for Engineered Wood Construction* is available from the American Wood Council of the American Forest & Paper Association. The *1996 LRFD Manual* consists of many parts. Embedded in its entirety within the *LRFD Manual* is *AF&PA/ASCE 16-95, Standard for Load and Resistance Factor Design (LRFD) for Engineered Wood Construction*. This standard carries with it the confidence of a consensus document that has undergone review and deliberations of a wide spectrum from engineers within the American Society of Civil Engineers (ASCE) and the American Forest & Paper Association (AF&PA). The other parts of the *LRFD Manual* include introductory information, case studies, examples, and explanations of basic design provisions. Also included as part of the Manual, but under separate cover, are a series of supplements and guidelines for different wood products and connections provided by various wood industry cooperators.

This manual is intended to illustrate design procedures for educational purposes and not to propose particular designs or design details. The financial support of the Wood Products Council (American Wood Council of the American Forest & Paper Association, Southern Pine Council (Southern Forest Products Association and the Southeastern Lumber Manufacturers Association) and the Wood Truss Council of America) made the development of this manual possible and is gratefully acknowledged.

Table of Contents

Problem 1. Wall Column Design	1
Problem 2. Solid Sawn Column Check	6
Problem 3. Bearing Check	10
Problem 4. Column Live Load Capacity	14
Problem 5. Floor Joist Check	19
Problem 6. Span of Floor Joist	24
Problem 7. Glued Laminated Timber Beam Check	29
Problem 8. Required Section Properties for SCL Beam	41
Problem 9. Walkway Plank Check	46
Problem 10. Cantilevered Glulam Beam Design	51
Problem 11. OSB Floor Panel Design	57
Problem 12. OSB Sheathing Design	61
Problem 13. Biaxial Beam Column Check	65
Problem 14. Biaxial Beam Column Maximum Load	73
Problem 15. Tension-Bending Member Design	81
Problem 16. Nail Splice Joint Check	87
Problem 17. Lateral Load on Spikes Design	93
Problem 18. Toe Nailing Design Check	100
Problem 19. Bolted Splice Joint Check	105
Problem 20. Bolted Connection Design	112
Knee Brace Problem Set	127
Problem 21. Knee Brace Bolted Connection Design	127
Problem 22. Knee Brace Design Check	134
Wood Frame Problem Set	138
Problem 23. Glued Laminated Timber Beam Design	139

Problem 24. Glued Laminated Timber Beam Design	147
Problem 25. Glued Laminated Timber Beam-Column Design	152
Concrete Formwork Problem Set	160
Problem 26. Formwork Sheathing Check	161
Problem 27. Formwork Stud Check	165
Problem 28. Formwork Wale Design	169
Long Span Truss Problem Set	174
Problem 29. Truss Top Chord Design	175
Problem 30. Truss Tension Web Connection Design	186
Problem 31. Truss Tension Web Design	190
Glulam Light Structure Problem Set	196
Problem 32. Light Pole – Curved Section Check	196
Problem 33. Light Pole – Straight Section Check	201
Small Warehouse Problem Set	207
Problem 34. Roof Diaphragm Nailing Design	208
Problem 35. Tension Chord Check	212
Problem 36. Holddowns for Walls A and B as Type I Walls	214
Problem 37. Holddowns for Walls A and B as Type II Walls	220
Problem 38. Anchor Bolt Design for Wall A	225
Problem 39. Shear Wall A Nailing Schedule	230
Problem 40. Design Equation Derivation	232
Index	238

Problem 1. Wall Column Design

Pick the appropriate size and grade of the 2-in by ___ Southern Pine column used in a dry environment. The column is 12-ft long, simply supported and supports unfactored axial loads of 500-lb dead, 800-lb live and 4,000-lb snow. Full lateral support is provided by sheathing preventing buckling about the nominal 2-inch direction.

Problem 2. Solid Sawn Column Check

What is the largest factored axial force that can be applied to the nominal 6-in. by 6-in. Hem-fir column? Environmental conditions result in equilibrium moisture content of 25% and room temperature conditions.

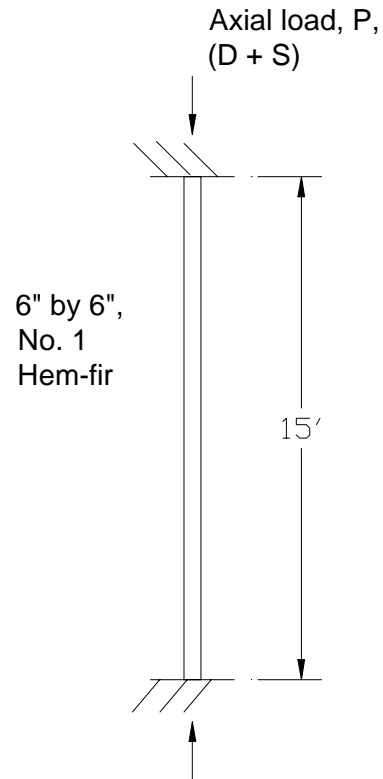

Problem 3. Bearing Check

Check the adequacy of the truss top chord bearing on the nominal 2-inch by 4-inch top plate in the wall. The structure is not exposed to weather or unusual temperatures. The loads shown are associated with load combination $1.2D+1.3W$ and are factored resulting in the values shown. The truss top chord is a nominal 3-inch by 6-inch S-P-F Select Structural and the top plate is a nominal 2-inch by 4-inch Southern Pine No. 3.

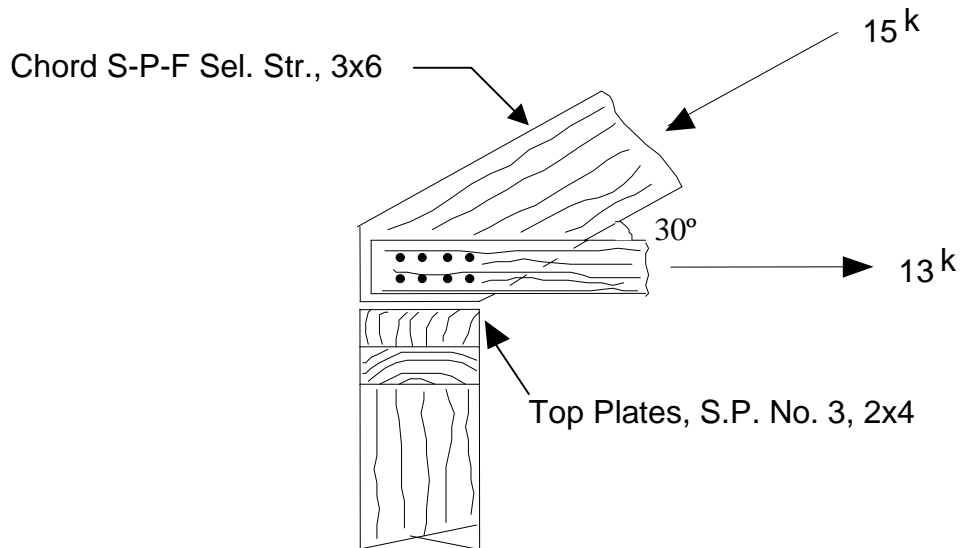

Problem 4. Column Live Load Capacity

A column is a nominal 6-in. by 10-in., dense No. 1, Douglas-fir Larch, exposed to weather in service. The member is 25-ft long with the bottom embedded and the top braced against sidesway in the nominal 6-inch direction. The member has been preservative treated according to provisions of the American Wood Preservers' Association with 0.40 lbs/ft³ for ground contact. What is the unfactored live load capacity if the dead load is 2,000 lbs (unfactored)?

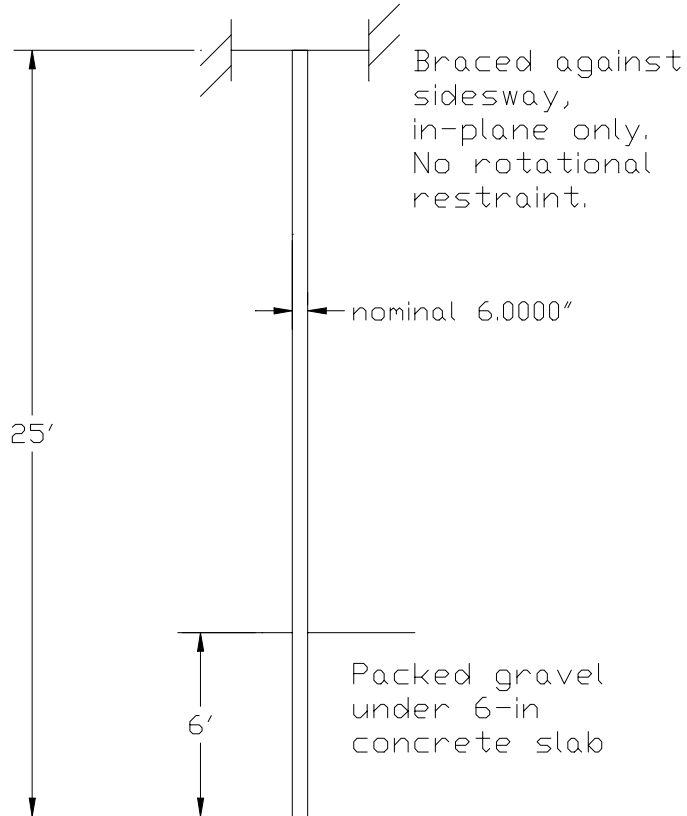

Problem 5. Floor Joist Check

Check the adequacy of the floor joist as shown. The joist consists of a nominal 2-in. by 10-in. member of No. 2 Southern Pine and contains a notch at one end. The joists are spaced at 24 inches on center and are sheathed on the top with structural wood panels that are attached with nails. The joists are within the interior of a building and subject to standard moisture conditions. The deflection of the joists must be $L/360$ or less when subject to unfactored live load.

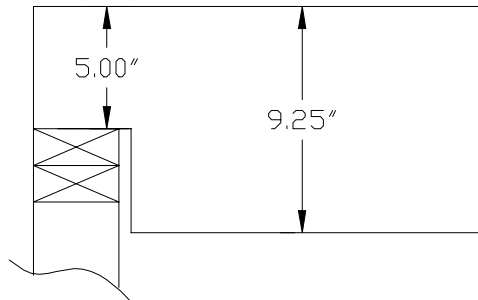
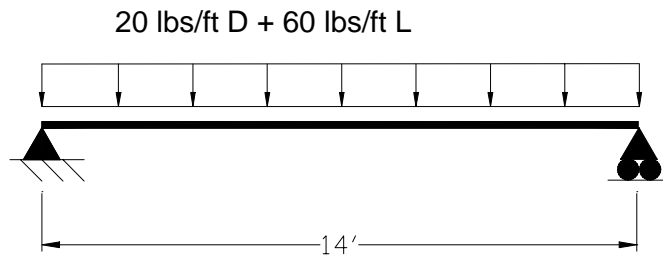

Problem 6. Span of Floor Joist

Find the maximum (simple) span of a floor joist consisting of a nominal 2-in. by 12-in. No. 2, Hem-Fir spaced at 16 inches on center to carry unfactored dead load of 10 psf and live load of 40 psf. The moisture content is less than 19% max and deflection limit is span/240 for total unfactored load.

Problem 7. Glued Laminated Timber Beam Check

The glued-laminated timber roof beam is subjected to factored loads as shown; these include the beam dead load. The time effect factor, λ , is 0.8. The 24-ft beam is laterally supported at its ends only and there is no intermediate lateral support. The beam is Douglas-fir 24F-V5 grade and has a 6-3/4-in. by 24-in. cross section. If we ignore the torsion produced by the 0.1 k/ft load, determine if the beam is adequate. If it is not adequate, then what size beam would be required?

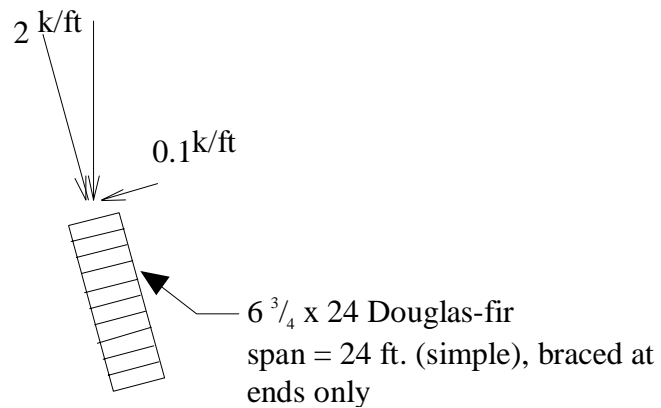

Problem 8. Required Section Properties for SCL Beam

A floor system is to be designed with structural composite lumber (SCL) members spaced at 2-ft on centers and with a simply supported span of 18 ft. The floor has properly nailed wood structural panels that have been designed to carry the 15 psf dead load and 100 psf floor live load (unfactored loads). The sheathing provides full lateral support. It is assumed that the manufacturer's literature for the structural composite lumber beam provides normal duration allowable stresses and material properties as follows:

$$\begin{array}{ll} F_b = 1850 \text{ psi} = 1.85 \text{ ksi} & E_{\text{apparent}} = 1,518,000 \text{ psi} = 1,518 \text{ ksi} \\ F_v = 350 \text{ psi} = 0.35 \text{ ksi} & G = 103,125 \text{ psi} = 103 \text{ ksi} \end{array}$$

Determine the required minimum section properties to satisfy bending, shear, and an $L/240$ (unfactored $D+L$) deflection criterion.

Problem 9. Walkway Plank Check

An elevated walkway exposed to the weather is constructed of preservative treated Southern Pine Lumber. The surface is constructed of 12-ft long by nominal 2-inch by 6-inch No. 2 Nondense lumber oriented flatwise and spaced $\frac{1}{4}$ -in apart edge to edge. Supports are provided every 6-ft. Design specifications call for the walkway to support an unfactored design live load of 60 psf with an unfactored dead load of 5 psf and that short-term design deflection be less than span/360 when subject to unfactored live load only. Do not consider pattern loadings. Determine the adequacy of the walkway plank.

Problem 10. Cantilevered Glulam Beam Design

Select the size of the glued laminated beam to resist an unfactored uniform dead load of 20 lb per foot (includes beam self-weight) and 180 lb per foot of snow load. Full lateral support is provided with certainty only at the pin and roller supports. Normal temperature and dry conditions prevail. Use visually graded Southern Pine combination 20F-V5. Do not check bearing and deflection.

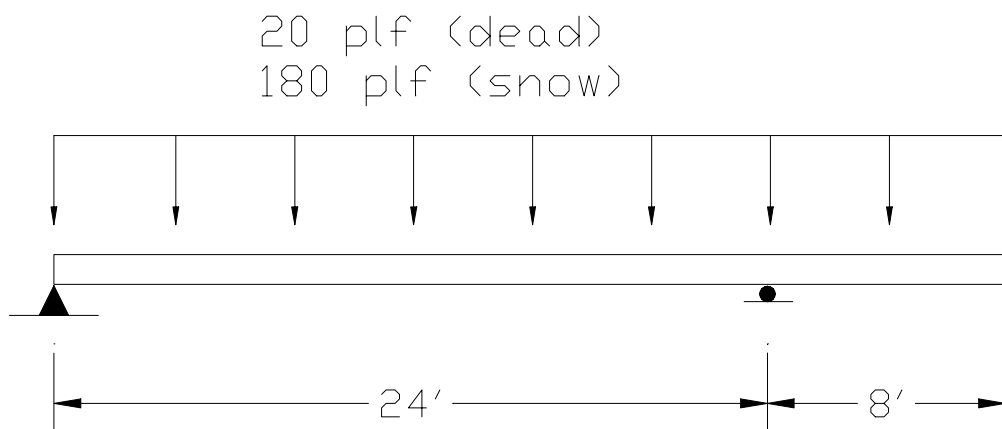

Problem 11. OSB Floor Panel Design

The floor sheathing in a corridor of a building is to be sized for load combination $1.2D + 1.6L$ and $\text{span}/240$ deflection criterion (using unfactored loads). Oriented strand board sheathing (OSB) is to be used over nominal 2-in. framing members that are spaced 24 in. apart; the sheathing is placed so that the 8-ft dimension is perpendicular to the framing members. Determine the sheathing thickness if the unfactored dead load is 10 psf and live load from occupancy is 100 psf.

Problem 12. OSB Sheathing Design

As part of a remodeling job, you are to design an oriented strand board sheathing (OSB) subfloor for the stage of the local civic center. Select the appropriate span rating and thickness of panels, and specify how the panels are oriented and placed. Supporting members are nominal 2-by members placed 24-inches on center. For dead load assume 5 psf to be adequate. Choose the appropriate unfactored design live load from ASCE 7¹. Deflections should be limited to $L/360$ for unfactored live load only.

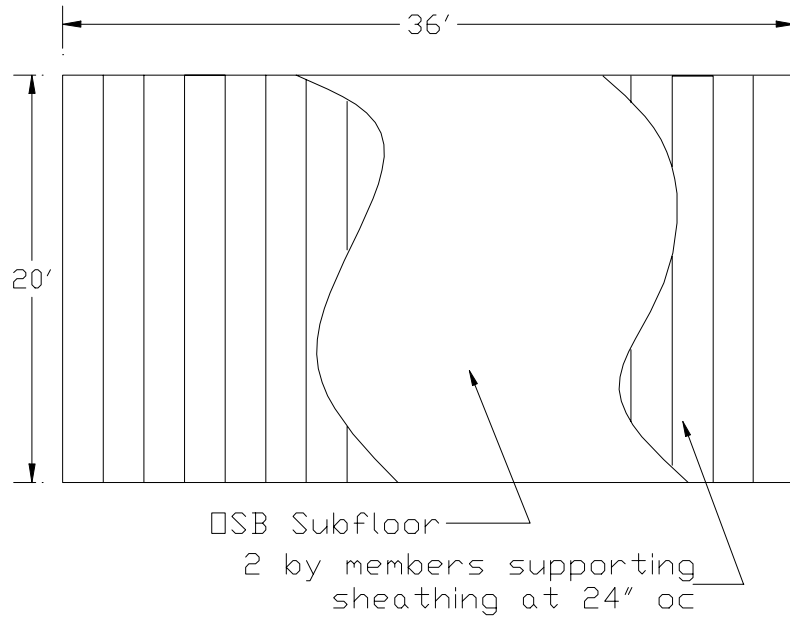

¹ AF&PA/ASCE Standard 16-95 is based on ASCE 7-93. American Society of Civil Engineers. 1993. Minimum Design Loads for Buildings and Other Structures. ASCE 7-93. New York, NY. More recent issues of this standard may be available.

Problem 13. Biaxial Beam Column Check

A treated No. 1-Dense, nominal 4-inch by 12-inch (structural lumber) Southern Pine member is 12-ft long above grade. It is embedded at the base providing approximate fixity and it is free to undergo sidesway about the strong axis of bending at the top. The preservative treatment meets American Wood Preservers' Association standards with 0.40 lbs/ft³ retention for ground contact. Lateral bracing about the weak direction of bending is provided every 4 ft. An unfactored uniform wind load of 160 lb/ft causes strong axis bending, but the sheathing to which the wind load is applied is not connected to the column in such a way as to provide lateral support. An unfactored axial dead plus snow load ($D=0.5$ kips+ $S=4.2$ kips) acts at an eccentricity of 1 inch inducing bending about the weak axis. Determine the adequacy of the 4-inch by 12-inch lumber member.

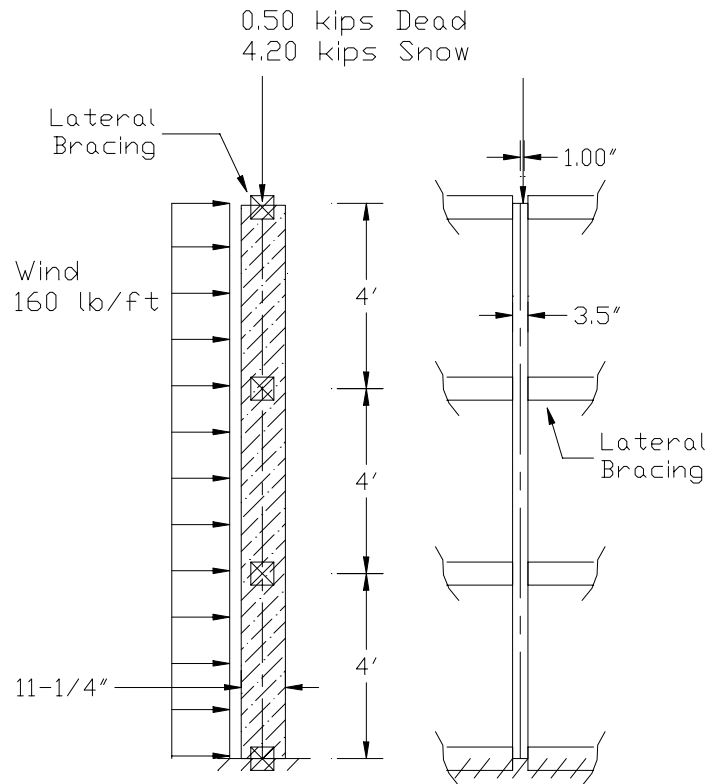

Problem 14. Biaxial Beam Column Maximum Load

Determine the maximum unfactored wind load that can be sustained by the column in Problem 13.

Problem 15. Tension-Bending Member Design

A Southern Pine member of Combination 24F-E1 will serve as a portion of the bottom chord of a truss with loads as shown in the attached sketch. The load combination, $1.2D+1.6L_r$, is known to control and the loads already have been appropriately factored. Lateral support is provided every 4-ft. by bracing. If the bottom chord is 5-in. wide, determine the required depth to satisfy interaction and shear force demands.

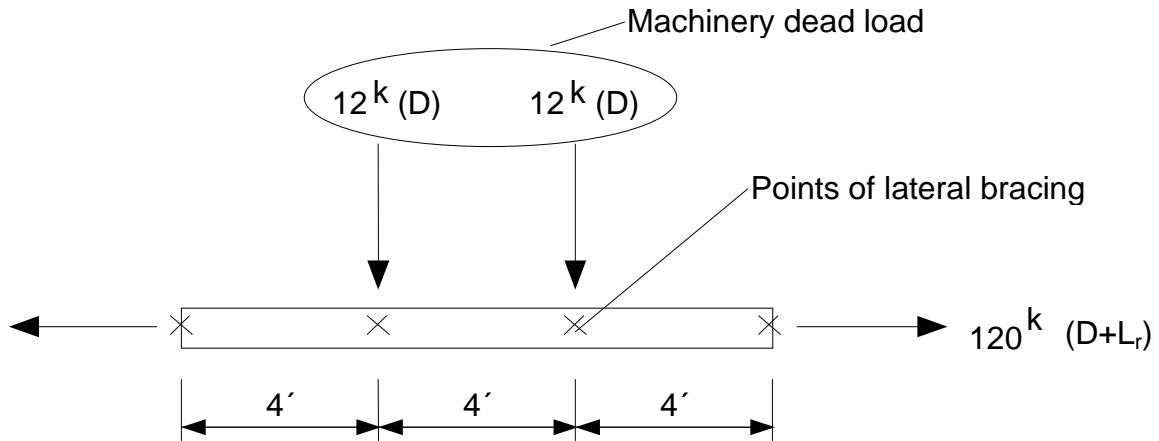

Problem 16. Nailed Splice Joint Check

Determine the tensile capacity (maximum factored load) of the splice joint connecting two nominal 2-inch by 6-inch Southern Pine members together. Eighteen 8d common nails are used on each face of the splice. Specify spacings needed to achieve maximum capacity.

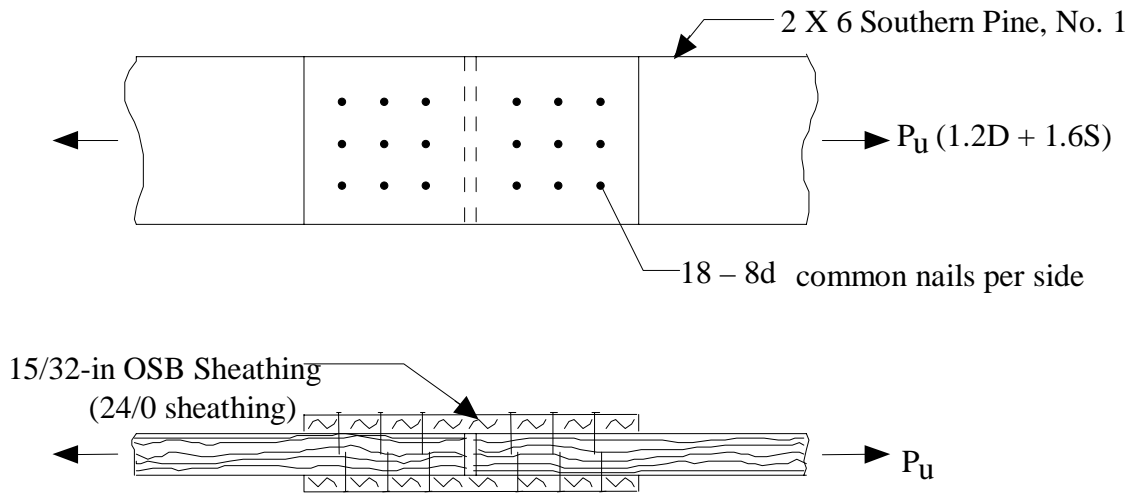

Problem 17. Lateral Load on Spikes Design

Determine the number and placement of spikes to transfer the unfactored 1.2 kip wind load from the diagonal to the vertical. Wood is seasoned Southern Pine that will remain dry. The nominal 2-inch by 6-inch member forms a 45-degree angle with the 4-inch by 10-inch member.

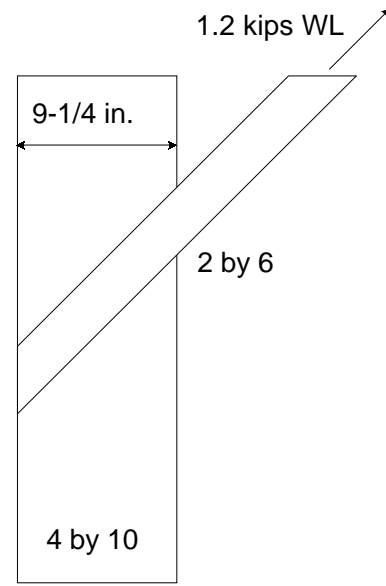

Problem 18. Toe Nailing Design Check

Determine if the nails provide adequate lateral resistance to hold the wall stud in place when subject to a wind load. The 10-ft Southern Pine stud is toe nailed into Southern Pine top and bottom plates with two 10 penny box nails at the bottom and the same arrangement at the top. The unfactored wind load is 32 psf and the studs are spaced 16-inch on center. The connections are dry and the nails are adequately spaced.

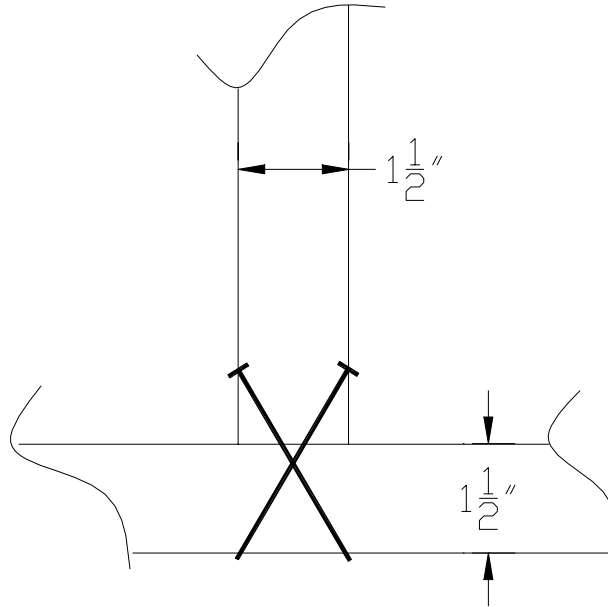

Problem 19. Bolted Splice Joint Check

The bolted splice joint consisting of 1-inch diameter bolts and nominal 2-inch by 12-inch No. 2, Southern Pine lumber, is fabricated wet and used where exposed to weather. Assuming load combination $1.2D+1.6S$ controls, determine the capacity of the connection (maximum factored load).

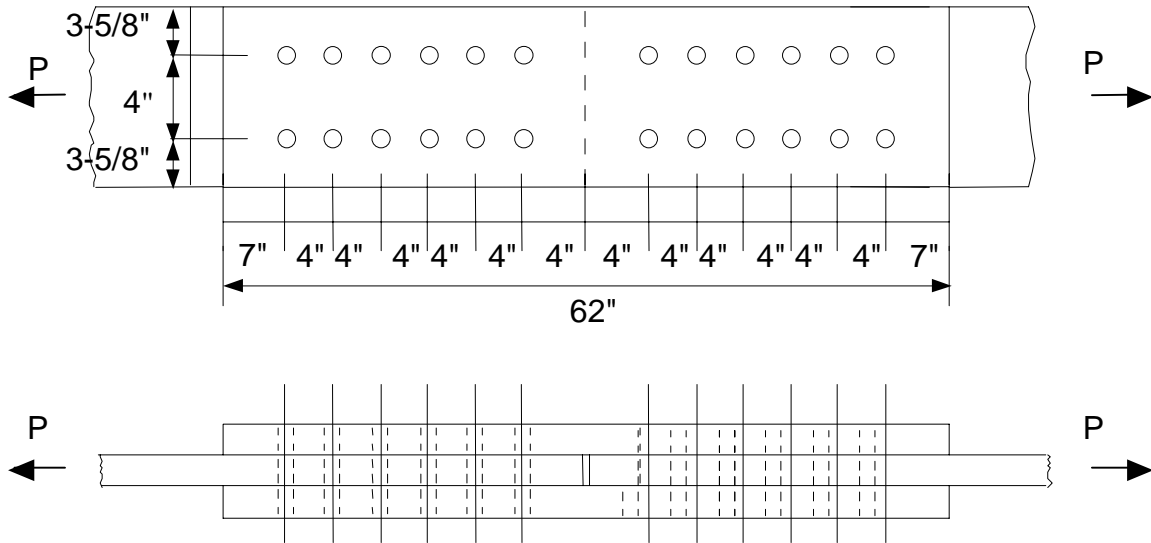

Problem 20. Bolted Connection Design

Determine the size, number, and placement of bolts needed to transfer an unfactored 2.8-kip snow load through the joint shown. The nominal 6-inch by 10-inch Hem-fir No. 1 seasons in place but remains dry in service. The nominal 2-inch by 6-inch members are kiln-dried Southern Pine No. 1.

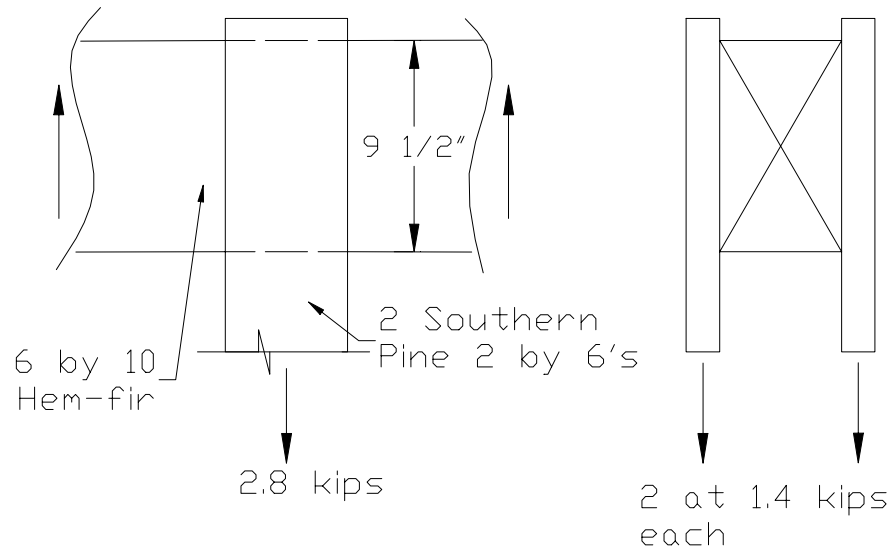

Problem 21. Knee Brace Bolted Connection Design

The knee brace shown in the figure experiences an unfactored axial load of 4.0 kips under a wind load event. Load reversals are possible so the 4.0 kip load can be tension or compression. Determine the size and number of bolts needed to resist this load. As the knee brace will be in the interior of building, it will remain dry with normal temperatures. The knee brace is a 2-by-6 inch, M-12 Southern Pine and is sandwiched between a double 2 by 10 spaced column post and a double 2 by 8 truss bottom chord. The post and bottom chord are also Southern Pine MEL lumber.

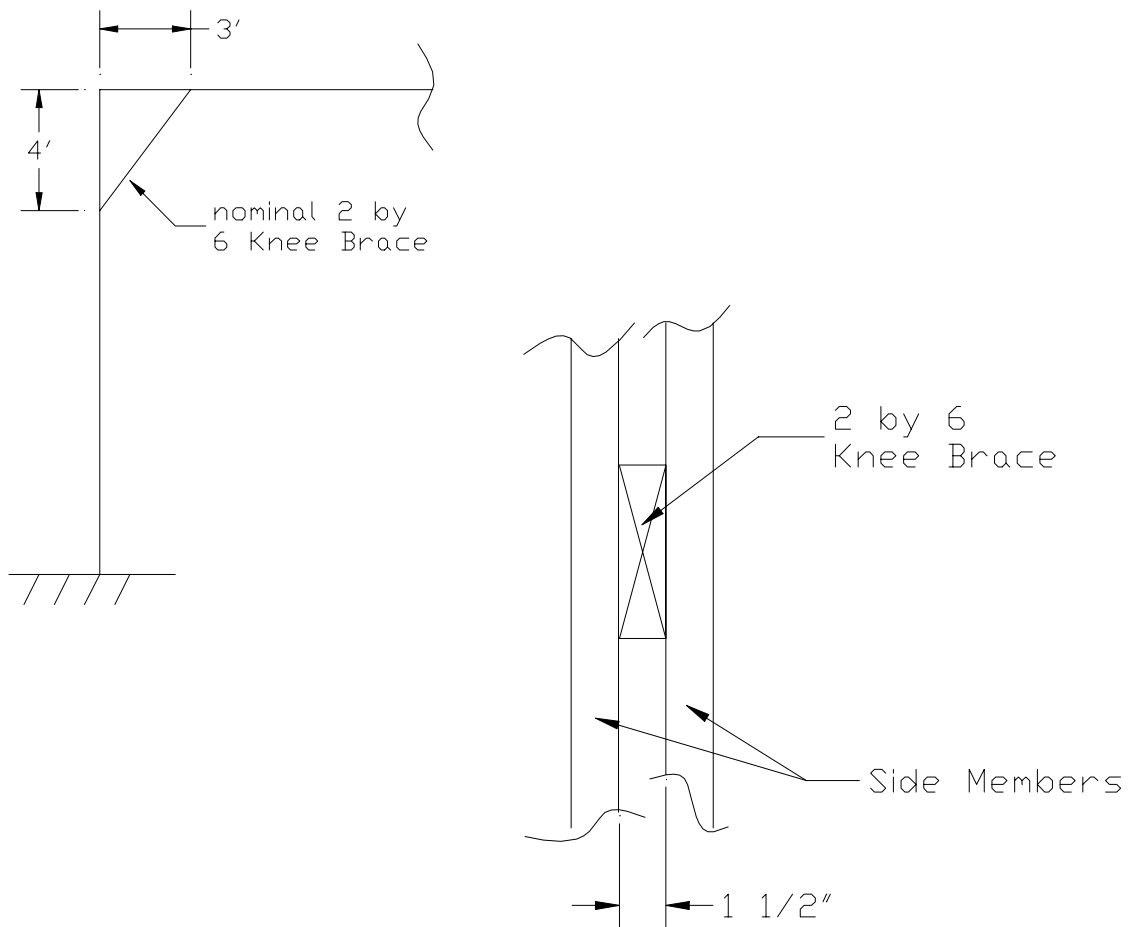

Problem 22. Knee Brace Design Check

As in the previous problem, the knee brace shown in the figure experiences an unfactored axial load of 4.0 kips under a wind load event. Load reversals are possible so the 4.0 kip load can be tension or compression. Determine the adequacy of the knee brace assuming two bolts connect the knee brace at the top and the bottom (see Problem 21). As the knee brace will be in the interior of building, it will remain dry with normal temperatures. The knee brace is a 2-in. by 6-in., M-12 Southern Pine and is sandwiched between a double 2-in. by 10-in. spaced column post and a double 2-in. by 8-in. truss bottom chord. The post and bottom chord are also Southern Pine MEL lumber.

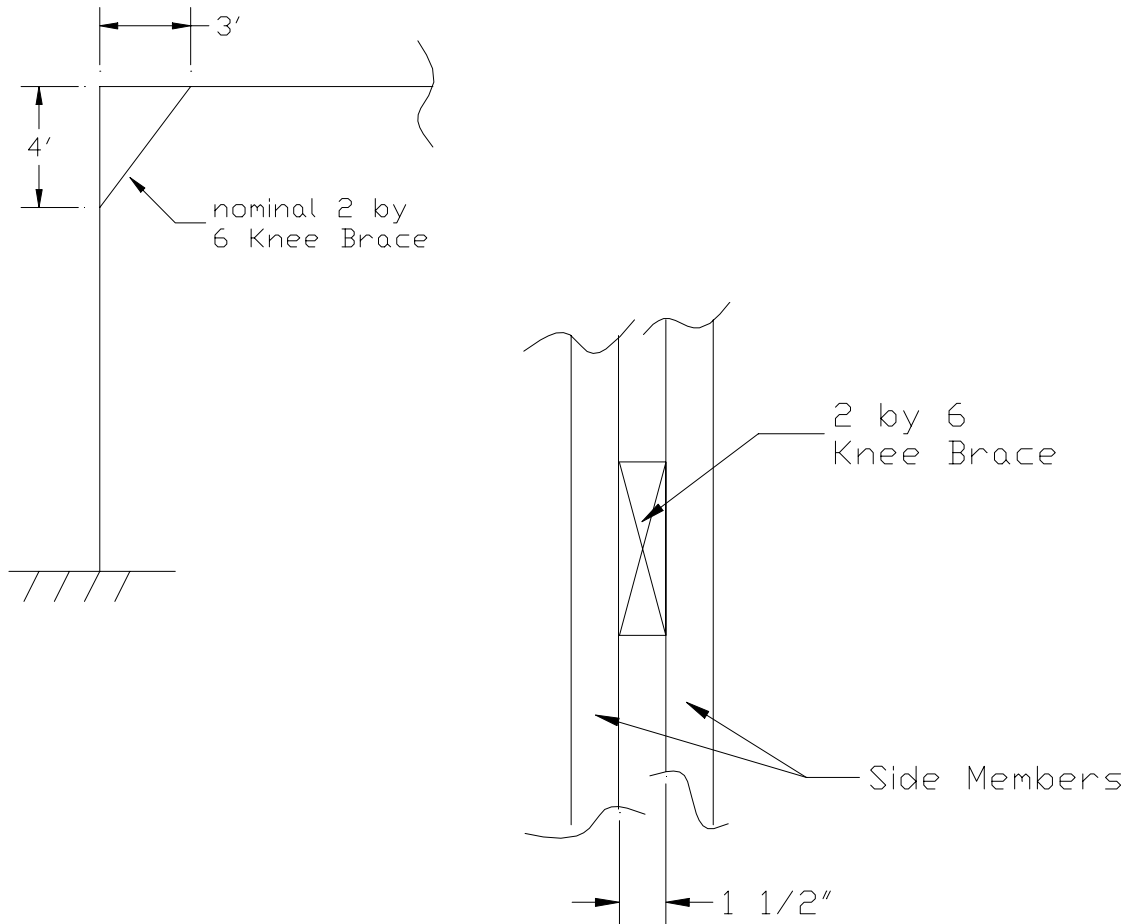

Wood Frame Problem Set

A set of problems relate to the beams and column assembly shown below. Beams A and B both rest on the end of Column A in such a way that each of the three members may be considered pinned at the point where they meet. Beams A and B are centered on the column so they do not induce bending into the page. All loads are unfactored.

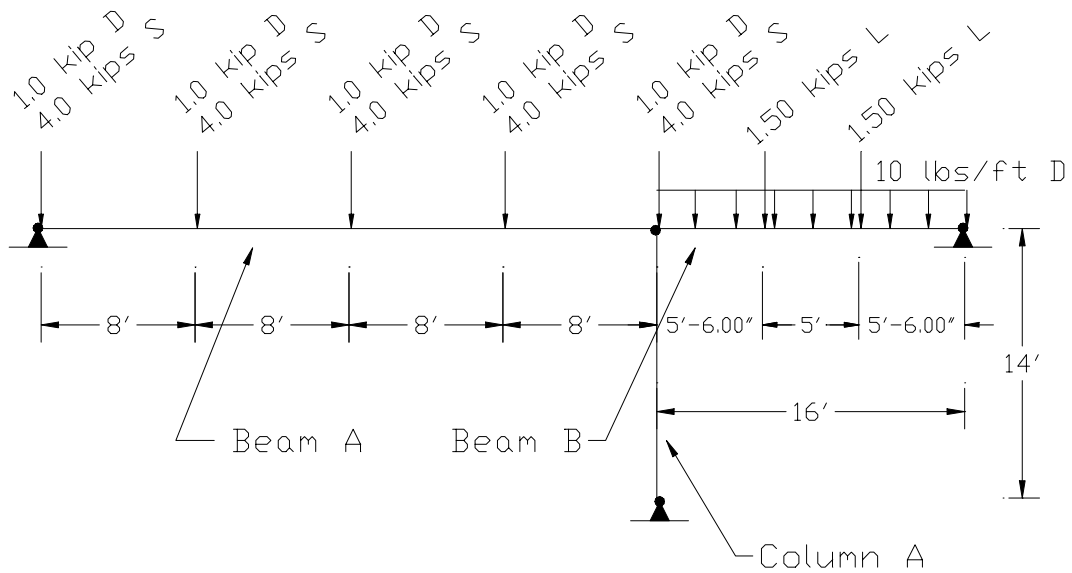

Problem 23. Glued Laminated Timber Beam Design

Design beam A spanning 32 ft with unfactored 5.0-kip loads (1.0 kip dead load + 4.0 kip snow load) applied by purlins spaced 8-ft on center (problem set figure). The member has lateral support at the ends and at locations where the purlins frame into the beam. Beam bearing supports are 5 inches long. Dry service conditions prevail and temperatures are generally less than 100°F but occasionally may reach 150°F. Use 24F-V1 Southern Pine glued laminated timber. Beams A and B both rest on the end of Column A in such a way that each of the three members may be considered pinned at the point where they meet.

Problem 24. Glued Laminated Timber Beam Design

Size beam B shown in the problem set figure. Use 20F-E2 Western Species glued laminated timber. Lateral support is provided at the ends of the beam and locations of the live loads. Assume bearing lengths are 4 inches long. Moisture content will be 15% or less and normal temperatures exist.

Problem 25. Glued Laminated Timber Beam-Column Design

Consider Column A in the figure for the problem set. Choose the size of an E-rated Southern Pine column using Combination 54. Assume that Beams A and B bear on top of Column A in a steel saddle. Including a small spacing between the ends of the beams and given bearing lengths for each beam, Beam A acts at $2\frac{5}{8}$ inches and Beam B at $2\frac{1}{8}$ inches from the column centroidal axis. No adjustments are needed for environmental conditions.

Concrete Formwork Problem Set

The following set of problems pertains to design of sheathing, supporting studs and wales in the concrete formwork system shown below. Key design parameters are as follows:

- Single-use formwork system
- Wall is 14 ft. high
- Concrete placement temperature will be 60°F
- 5000-lb coil ties are used
- Unfactored load deflection limit is span/360
- All wood subject to wet use
- Concrete is placed at 3 ft/hr. of wall height
- Studs are spaced at 12 inches on center
- 3-¾ inch square tie washers bear on the wales with a ¾-inch spacing between the wales

Design of a concrete formwork system can be accomplished using provisions of the LRFD Manual, but additional information concerning loads generated by plastic concrete is also needed.

Sources for additional design guidelines specific to formwork include A. Hanna, *Concrete Formwork Systems*, Marcel Dekker, Inc. 1999 and M. Hurd, *Formwork for Concrete*, SP #4, 6th Ed., American Concrete Institute 1995.

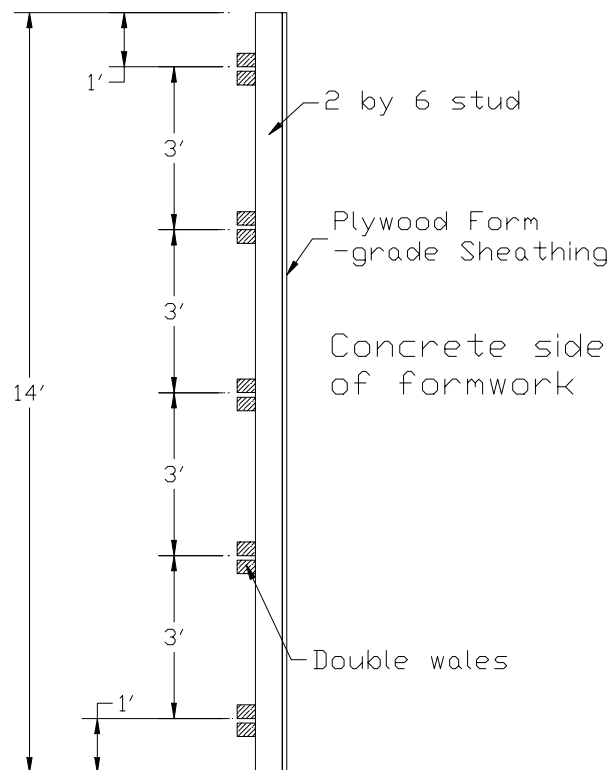

Problem 26. Formwork Sheathing Check

Determine the adequacy of $7/8$ -in. thick, form-grade plywood sheathing for the formwork system shown in the problem setup on the previous page.

Problem 27. Formwork Stud Check

Determine the adequacy of the studs spaced 12-in. on center and consisting of nominal 2-inch by 6-inch Southern Pine No. 1 members. The plywood sheathing is attached to the studs providing full lateral support.

Problem 28. Formwork Wale Design

Select a size and tie spacing for the double wales consisting of Southern Pine, Construction Grade, structural lumber in the concrete formwork system.

Long Span Truss Problem Set

A long span truss consisting of glued-laminated members and steel gusset plate connections has been analyzed and member forces have been determined for the snow load condition shown. In the analysis, it was assumed that joint details are such that the truss behaves as if pin-connected. The following problems pertain to design of several components of the truss. Member forces associated with two subsequent problems are shown in the figure.

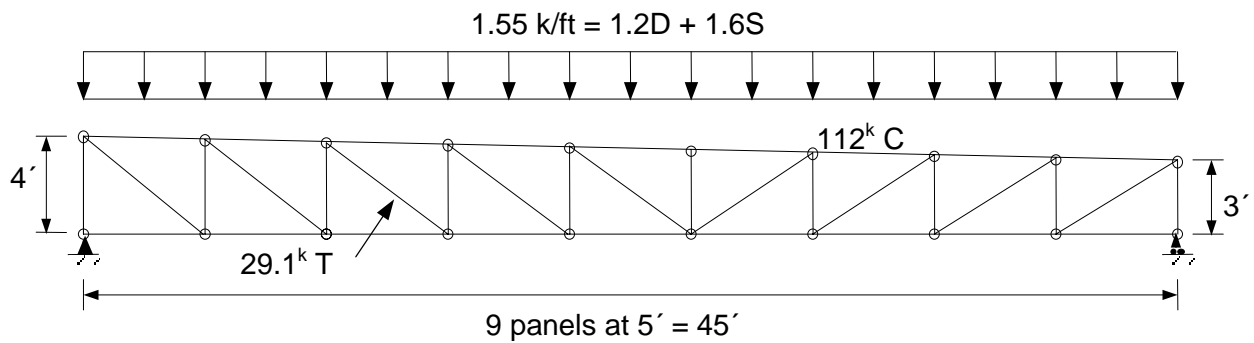

Problem 29. Truss Top Chord Design

A panel of the truss top chord consists of two 3-in. wide glulams spaced 3 in. apart to accommodate single member webs. The members are Douglas-fir Combination #31. The governing load combination is $1.2D+1.6S$ for the factored loads shown. Attached sheathing provides continuous bracing along the top. Determine the minimum required top chord depth based on axial and lateral force interaction only.

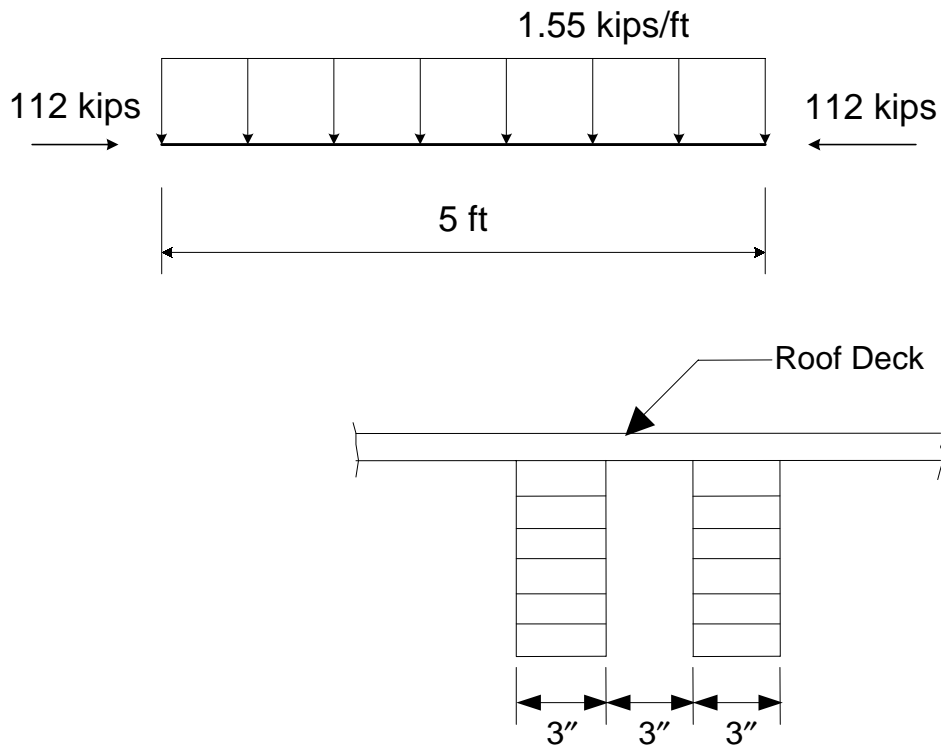

Problem 30. Truss Tension Web Connection Design

How many $\frac{3}{4}$ -in. diameter bolts are required to transmit a 29.14 kip tensile force (from factored loads) to the joint if a $\frac{1}{4}$ -in. thick steel (ASTM A36) gusset plate is used on each face of the joint? The web has a thickness into the page of 3-in. and consists of Southern Pine glulam. Assume the web will be sized appropriately to meet net section demands. The governing load combination for the connection is $1.2D + 1.6S$.

Problem 31. Truss Tension Web Design

Determine minimum member depth for the tension web that is 3-in. wide (into the page) and must resist a tensile force of 29.14 kips. In the determination of the member depth, consider the $\frac{3}{4}$ " ϕ bolts from the previous problem, their optimal spacing requirements, and a net section check. Detail the joint. The wood is Southern Pine glued laminated timber, Combination #56.

Problem 32. Light Pole – Curved Section Check

Check the curved portion of the light pole for bending, shear, and radial stress if a 200-lb (unfactored) light fixture is hung from the pole tip. Assume exterior exposure and temperatures less than 100°F. Consider only dead load and neglect axial-bending interaction.

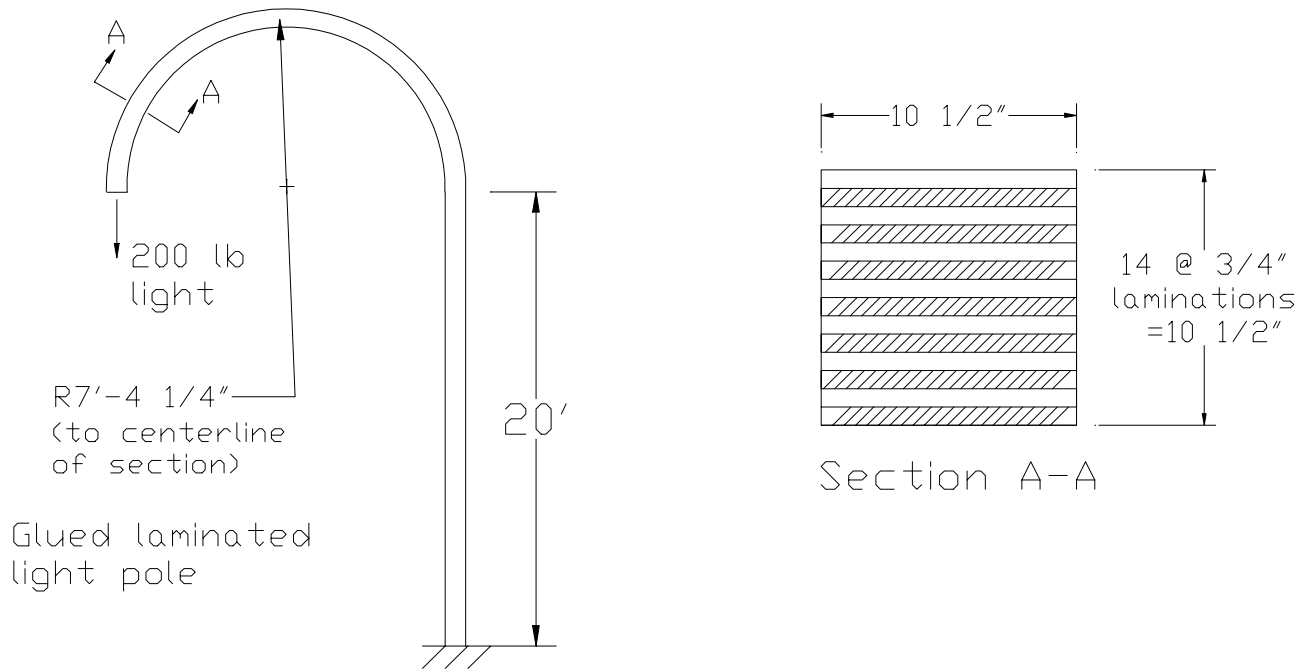

Problem 33. Light Pole – Straight Section Check

Check the adequacy of the straight, vertical portion of the light pole for combined bending and axial force interaction. Assume exterior exposure and temperatures less than 100°F. Consider only dead load.

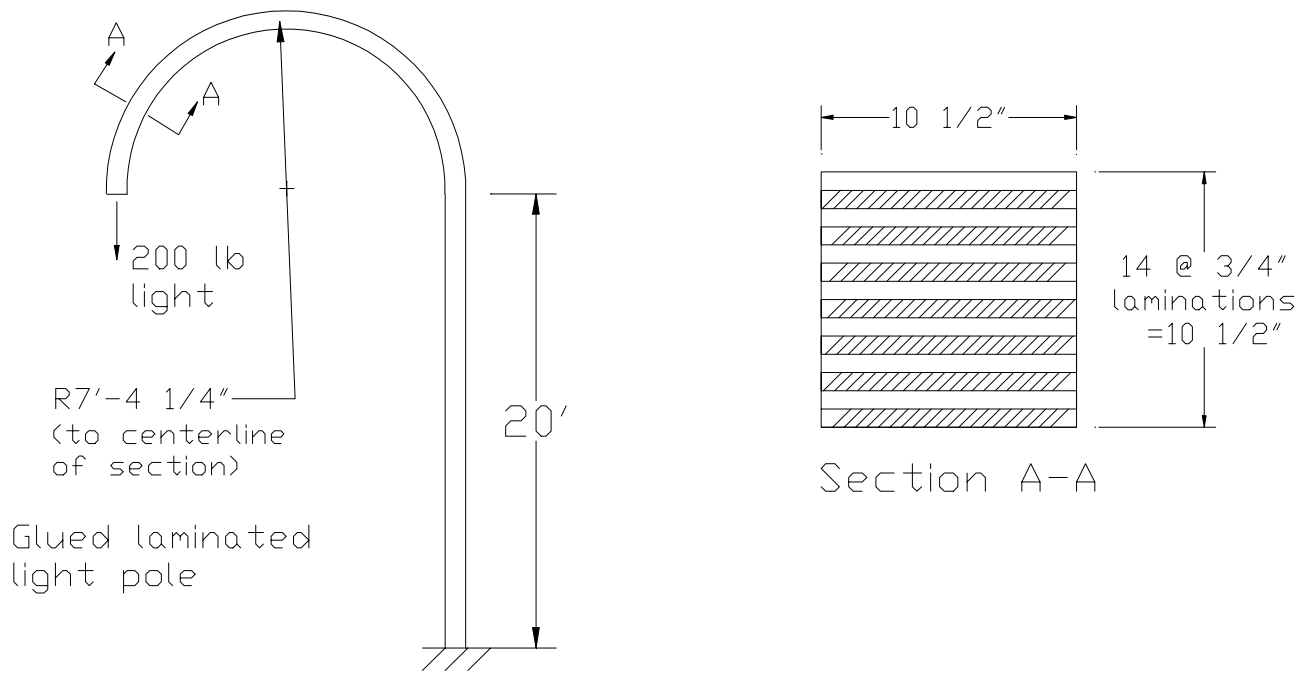

Small Warehouse Problem Set

The small building shown is in an environment with a 90 mph wind speed. The following six problems are associated with this structure. *The Wood Frame Construction Manual*¹ will be used to determine the wind loads. It is assumed that the structure rests on a reinforced concrete foundation and that all the wood framing and sheathing is Southern Pine.

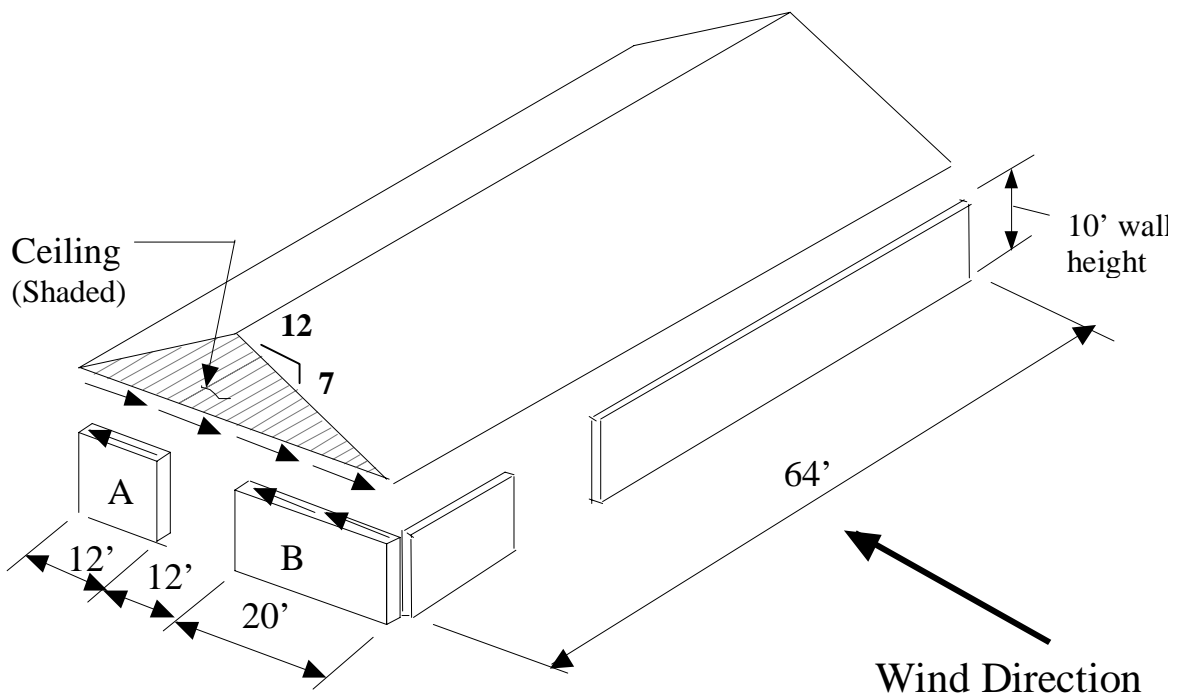

¹ American Forest & Paper Association. 1996. *The Wood Frame Construction Manual for One- and Two-Family Dwellings, 1995 SBC High Wind Edition*. American Wood Council. American Forest & Paper Association, Washington DC.

Problem 34. Roof Diaphragm Nailing Design

Assume that the 90 mph wind load is perpendicular to the ridge of the structure. Determine the nailing schedule for the roof diaphragm for $1.2D + 1.3W$; assume the diaphragm is unblocked and that nails are 8d common. The sheathing is southern pine and it is placed so that the long edge is perpendicular to prefabricated roof trusses. Thus, all edges parallel to the wind load will be blocked, but those edges perpendicular to the wind load will not be blocked. This will be Case 1 for the unblocked diaphragms in Table 5.5 of the Panel Supplement. Assume that the roof trusses are spaced at 2 ft o.c. and that the nominal thickness of the top chord members is 2 in. Dry conditions and room temperatures prevail. All wood framing is southern pine.

Problem 35. Tension Chord Check

Assume that the chords of the roof diaphragm consist of two No. 3 grade Southern Pine 2 x 4 members. Check the adequacy of the chord for axial tension only.

Problem 36. Holddowns for Walls A and B as Type I Walls

Holddowns are to be designed to prevent Wall A from overturning. If the holddowns are 10 ga. ASTM A446 Grade A steel straps, how many 16d common nails are required to attach the steel strap to the wood 4-in by 4-in chord of the wall.

Problem 37. Holddowns for Walls A and B as Type II Walls

As in Problem 36, 10 ga. steel straps are used as anchors to prevent overturning. Considering the walls as Type II, how many anchors are required and how many 16d common nails are required with them?

Problem 38. Anchor Bolt Design for Wall A

Determine the required number of $\frac{3}{4}$ -in. diameter bolts to anchor Wall A to a reinforced concrete foundation.

Problem 39. Shear Wall A Nailing Schedule

Determine the nailing schedule for Wall A as a Type I shear wall. Assume the studs are 2 x 4 spaced at 16 in. and the nails are 8d common. All wood is Southern Pine.

Problem 40. Design Equation Derivation

LRFD Standard Eq. 5.2-7 is shown below:

$$M_e = 2.40 E_y \frac{I_y}{l_e} \quad (\text{LRFD 5.2-7})$$

Show and explain the basis of this equation.

.....

Mission Statements



AF&PA/American Wood Council

To increase the use of wood by assuring the broad regulatory acceptance of wood products, developing design tools and guidelines for wood construction, and influencing the development of public policies affecting the use of wood products.

The **American Wood Council** (AWC) is the wood products division of the American Forest & Paper Association (AF&PA). AF&PA is the national trade association of the forest, paper, and wood products industry, representing member companies engaged in growing, harvesting, and processing wood and wood fiber, manufacturing pulp, paper, and paperboard products from both virgin and recycled fiber, and producing engineered and traditional wood products. AF&PA represents a segment of industry which accounts for over 8% of the total U.S. manufacturing output.



Southern Forest Products Association

The mission of the Southern Forest Products Association is to maintain current markets, develop and expand new market opportunities for Southern Pine forest products, and to engage in such activities and programs that the members deem useful to advance and protect their interests.



Wood Truss Council of America

The Wood Truss Council of America (WTCA) is the only association directed by component manufacturers for component manufacturers whose resources and focus are completely dedicated to advancing the interests of the entire component manufacturing industry.

WTCA's mission is to ensure growth, continuity and increased professionalism in our industry by formulating policy that protects and advances the interests of member manufacturers. This includes supporting research, development and testing of trusses that place the truss industry on a sound engineering basis and improve the quality and efficiency of our products, for the purpose of obtaining greater product acceptance and hence market expansion.

WTCA will be the information conduit for our membership by staying abreast of leading-edge issues and disseminating this information through educational seminars and our wood truss industry publication *WOODWORDS*.

**American Forest & Paper Association
American Wood Council
1111 19th Street, NW
Suite 800
Washington, DC 20036
www.awc.org**

**America's Forest & Paper People®
*Improving Tomorrow's Environment Today®***

